

No part of this handbook may be reproduced,
transcribed, translated into any language or transmitted
in any form whatsoever without the prior written
consent of Codan Pty Ltd.

© Copyright 1994 Codan Pty Ltd.

Codan Part No. 15-04034 Issue 3, September 1995

Contents

1. About this handbook.....	1-1
Who should use this handbook	1-1
Icons and standards.....	1-1
Glossary	1-2
2. Overview	2-1
The Radiophone front panel	2-4
The transceiver and control head rear panels.....	2-8
3. Installation	3-1
Mounting the transceiver	3-2
Mounting the control head.....	3-3
Mounting the antenna	3-5
Mounting the loudspeaker	3-5
Power supply	3-6
Grounding.....	3-7
4. Using the Radiophone	4-1
Switching the Radiophone on or off	4-2
Switching on or off without a PIN	4-2
Switching on or off with a PIN.....	4-3
The Radiophone display	4-4
Option codes	4-4
Displaying the channel option.....	4-5
Dimming the display indicators	4-6
Reviewing the EPROM version and options.....	4-7

Selecting channels 4-9
 Using the Channel \wedge or \vee buttons 4-9
 Using the Select Channel button 4-10
 Adjusting the volume 4-11
 Using the clarifier 4-12
 Using the mute controls 4-13
 Voice mute 4-13
 Selective call mute 4-13
 Tuning the antenna 4-14
 Receiver tuning mode 4-15
 Using the Receiver Tuning \wedge or \vee buttons 4-16
 Selecting the desired frequency 4-17
 Storing a tuned receive only frequency 4-19
 Changing the operating mode (USB - LSB) 4-20
 Transmitting 4-21
 Using the microphone 4-21
 Transmitting a message 4-22

5. Using selective call 5-1

Selective call terms 5-2
 Setting up selective call 5-4
 Setting the pre-amble time period 5-5
 Setting the fixed called address 5-6
 Setting the self-identification address 5-7
 Enabling the beacon mode 5-7
 Setting tone calls 5-8
 Checking if a channel is enabled for selective call 5-9
 Selective call mute enable or inhibit 5-10
 Enabling a channel for selective call 5-12
 Transmitting a selective call 5-14
 Receiving a selective call 5-17
 Answering a received call 5-19

Returning a received call—general..... 5-20
 Reviewing the list of received calls in memory 5-21
 Reviewing calls held in memory 5-22
 Recalling calls held in memory 5-24
 Using the beacon feature..... 5-25
 Selective beacon mode..... 5-27
 (99) beacon mode..... 5-29
 Using the external alarm feature 5-31
 Testing the selective call functions 5-32

6. Using the receiver in scan mode 6-1

Scan mode terms..... 6-2
 Setting up the scan mode 6-3
 Programming the channels to be scanned 6-5
 Receiving in scan mode 6-7
 Start scanning..... 6-7
 Stop scanning 6-7
 Changing the scan mode..... 6-8
 Using selective call in scan mode 6-10
 Programming frequency band scan..... 6-12
 Scanning frequency bands 6-16
 Deleting unwanted scan channels 6-18

7. Programming channels 7-1

Setting up the P-channel inhibit options 7-2
 Checking if the inhibit link is fitted to the PCB 7-3
 Changing the inhibit options 7-4
 Copying channels to P-channels 7-6
 Creating receive only P-channels..... 7-9
 Deleting unwanted P-channels..... 7-11
 Programming display messages 7-12
 Setting up temporary channels 7-14

8. Using tone call	8-1
Setting up tone call	8-3
Enabling a channel for tone calling.....	8-6
Transmitting a tone call	8-9
9. Making a telephone interconnect call.....	9-1
Enabling the telephone mode.....	9-2
Making a telephone call.....	9-3
Sending a disconnect message	9-6
Storing a telephone number	9-8
Reviewing the stored telephone numbers.....	9-10
Calling a stored telephone number	9-12
Deleting a stored telephone number	9-15
Received call messages.....	9-17
Reviewing the list of received calls in memory	9-18
Returning a call.....	9-20
10. RFDS and Telstra services	10-1
Royal Flying Doctor Service	10-2
How to contact the RFDS	10-2
Emergency communications	10-2
Making an RFDS emergency call	10-4
Telstra Radphone Service.....	10-6
Transmitting a Telstra (OTC) selective call—selcall.....	10-7
Transmitting a Telstra selective beacon call.....	10-10
Receiving a Telstra selective call.....	10-12
Transmitting a Telstra (OTC) tone call.....	10-14

11. Changing the set-up options.....	11-1
Set-up option links.....	11-1
The control head link.....	11-2
Changing the position of the control head link.....	11-3
The microprocessor PCB link.....	11-4
Inserting the microprocessor PCB link.....	11-5
Reviewing set-up options.....	11-6
PTT timer.....	11-8
Enter a PIN (Personal Identification Number).....	11-10
Changing or deleting a PIN.....	11-12
Power-on settings.....	11-14
Mute settings.....	11-14
Beep volume.....	11-16
Clear all settings and P-channels.....	11-17
12. Display messages.....	12-1
Messages and operator errors.....	12-2
System errors.....	12-7
Reviewing the EPROM program content.....	12-8
13. Front and rear panel sockets.....	13-1
Microphone socket.....	13-2
External alarm socket.....	13-3
Antenna control socket.....	13-4
Remote control socket.....	13-5
14. Specification.....	14-1
15. Options and accessories.....	15-1

List of drawings

Figure	Title	Page
2.1	The control head front panel	2-7
2.2	The transceiver rear panel.....	2-9
2.3	The control head rear panel.....	2-9
3.1	Typical vehicle installation	3-1
9.1	Telephone interconnect block diagram	9-1
11.1	The control head link	11-2
11.2	The microprocessor link	11-4







1. About this handbook

Who should use this handbook

This handbook is written for the person who installs and operates the Codan Outback HF Radiophone.

Icons and standards

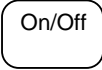
The following icons and standards have been used throughout this handbook.

This icon...	Means...
	the subject is continued over the page.
	the end of a subject.
	this is a warning, and information associated with this symbol must be adhered to.
	a button on the control panel.
	an antenna symbol used in drawings.

Glossary

AD	Antenna Driver
FEC	Forward Error Correction
LCD	Liquid Crystal Display
LSB	Lower Side Band
OTC	The corporate name for a Maritime Radphone service (superseded by Telstra)
PIN	Personal Identification Number
PS	Miscellaneous facilities
PTT	Press To Talk
R	Remote
RFDS	Royal Flying Doctor Service
Rx	Receive
SD	Selective call Decode
Telstra	The corporate name for a Maritime Radphone service (formerly OTC)
Tx	Transmit
USB	Upper Side Band



2. Overview

Your Outback HF Radiophone employs the latest concepts in design and reliability for long range communications. It has been designed for 12V DC operation in mobile installations.

The Outback HF Radiophone consists of a transceiver and a separate control head, automatic tuning whip antenna, vehicle mounting cradle, extension loudspeaker and all interface control and coaxial cables (6 metres).

It has been programmed with all the Royal Flying Doctor Service (RFDS) and Telstra (formerly OTC) frequencies suitable for operation into these services and any private frequencies that may have been requested at the time of purchase. In addition, the frequency program includes the CB (27 MHz) channels for USB-LSB operation. A comprehensive frequency list is supplied as a separate handbook.

You operate the transceiver through the control head, which contains sealed membrane switches (or buttons) and a liquid crystal display (LCD). The LCD shows the selected channel number along with the transmit and receive frequencies. In addition, the display shows messages about the operation of the transceiver.

Continual research and development has produced different versions of the transceiver. The different version means a later issue of EPROM which provides different operating features. To check the version of your transceiver, refer to section 4, *Reviewing the EPROM version and options*. This issue of the handbook incorporates operating information for EPROM version 4.3.

The main facilities and features of the Outback HF Radiophone are:

- channels
- selective call
- scanning
- free tuning receiver
- tone calling
- telephone interconnect
- OTC (Telstra) selective call.

Channels

Your transceiver has a capacity of 600 channels, these cover:

- transmit frequency range 2 MHz to 24 MHz
- receive frequency range 0.25 MHz to 30 MHz.

A maximum of 501 transmit and receive channels can be pre-programmed in the factory, or by an authorised Codan dealer. You, as a user, can program the remaining 99 receive only channels from the control panel as P-channels.

Selective call

This facility allows you to transmit a call to a single transceiver or a group of transceivers.

Your transceiver can store details of up to ten stations that have called you while your transceiver was left unattended.

Scanning

This facility scans selected channels for audio signals. You can program a maximum of 15 channels to be scanned in sequence for audio signals. The selective call facility allows a maximum of eight selective channels to be programmed and scanned.

- Free-tuning receiver** Your transceiver can be used as a free-tuning receiver covering the world broadcast bands over the frequency range of 250 kHz to 30 MHz.

- Tone calling** This facility allows you to send a tone call (two tones transmitted simultaneously) to call the RFDS or OTC (Telstra).





- Telephone interconnect** If a base station is connected to an IPC-500 telephone interconnect in a network, your Outback HF Radiophone can be used to make telephone calls into the public telephone system.

- OTC (Telstra) selective call** OTC (Telstra) selective call allows you to transmit a call to a specific Telstra station. The station then enables you to make telephone calls into the public telephone system.



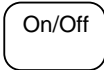

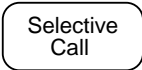

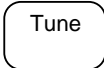
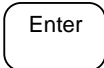
The Radiophone front panel



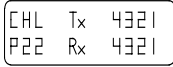



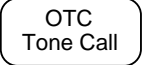

The front panel of the Radiophone control head (figure 2.1 on page 2-7) has the following designations:

Item No.	Item	Function
1		Switches the transceiver on or off.
2		The indicator is lit when the transceiver is transmitting.
3		Transmits a selective call to a selected OTC (Telstra) station.
4		Transmits either a selective call or tone call on the selected channel.
5		Selects USB or LSB mode.
6		Transmits a carrier signal so that the automatic antenna system can be tuned.
7		Sets the transceiver to accept programmed information.





Item No.	Item	Function
8		<p>Selects either channel or band scan. The indicator is lit when the scan mode is 'on'.</p>
9		<p>Liquid Crystal Display (LCD) shows the channel number and frequency. It also shows messages regarding the operation of the transceiver.</p>
10		<p>Mutes all audio until a selective call is received. The indicator is lit when the mute is 'on'.</p>
11		<p>Removes normal background noise when there is no audio signal. The indicator is lit when the mute is 'on'.</p> <p>In addition, it switches the selective call mute off.</p>
12		<p>Shows the options programmed for the selected channel exhibited on the LCD. It is also used to interrogate received selective call memory and selects a specific channel when used with the numeric buttons.</p> <p>In addition, it dims the display and indicators when pressed twice within one second.</p>
13		<p>Microphone socket.</p>



Item No.	Item	Function
14		Transmits a tone call to a selected OTC station.
15		Transmits a tone alarm call on selected frequencies operating within the Royal Flying Doctor Service of Australia.
16		Reduces the programmed frequency in steps of 1 kHz. It also keys in number 6.
17		Raises the programmed frequency in steps of 1 kHz. It also keys in number 1.
18		Reduces the programmed frequency in steps of 100 Hz. It also keys in number 7.
19		Raises the programmed frequency in steps of 100 Hz. It also keys in number 2.
20		Reduces the received audio frequency in steps of 10 Hz to help clarify the received speech. It also keys in the number 8.
21		Raises the received audio frequency in steps of 10 Hz to help clarify the received speech. It also keys in number 3.

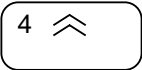

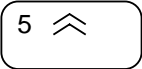
Item No.	Item	Function
22		Selects the next lower channel. It also keys in number 9.
23		Selects the next higher channel. It also keys in number 4.
24		Decreases the audio volume. It also keys in the number 0 and the letter P.
25		Increases the audio volume. It also keys in number 5.

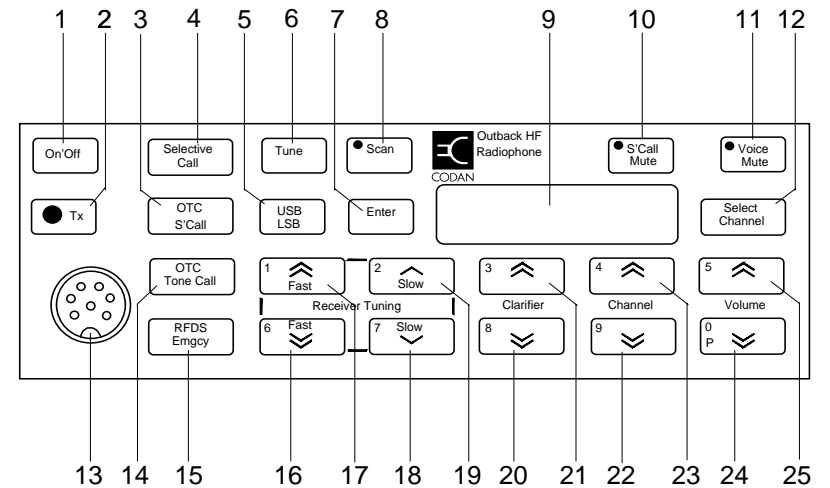

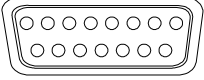

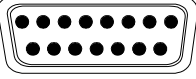



Figure 2.1: The control head front panel



The transceiver and control head rear panels

The transceiver and control head rear panels (figures 2.2 and 2.3 on page 2-9) show the following items:

Item No.	Item	Function
1		Antenna socket.
2		Earth (ground) screw.
3		Automatic antenna control socket.
4		12V DC power lead.
5		External 8 ohm loudspeaker socket.
6		Remote control unit socket.
7		External alarm socket.



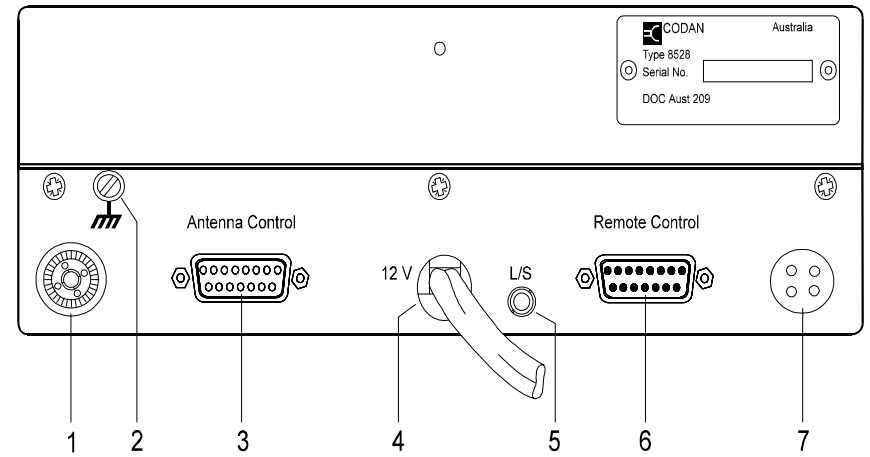

Figure 2.2: The transceiver rear panel

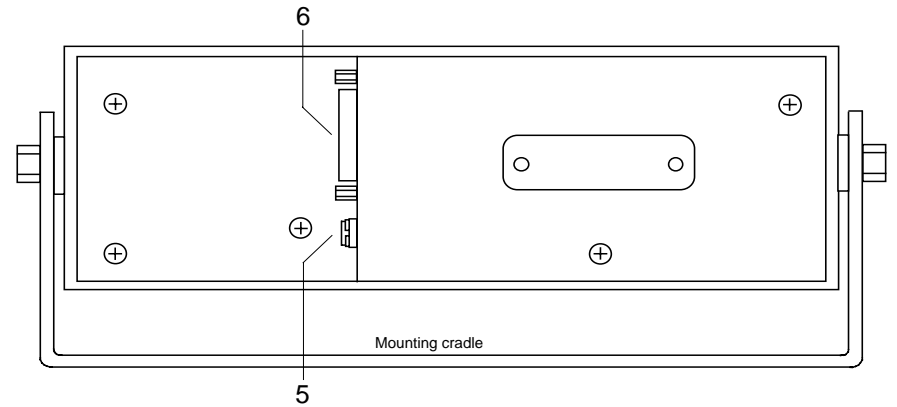

Figure 2.3: The control head rear panel



3. Installation

On receipt of your Outback HF Radiophone package, check the contents against the packing list. Ensure all items are available before commencing installation.

The following notes provide guidance to your vehicle installation but are not intended to be comprehensive procedures. It is recommended that installation is carried out by qualified and experienced personnel.

The vehicle installation (figure 3.1) typically consists of a 12V DC power supply (battery) connected to the transceiver with the automatic tuning antenna connected to the transceiver by coaxial cable and control cable.

The microphone is connected to the control head which, in turn, is connected to the transceiver. The speaker can be connected to either the transceiver or the control head.

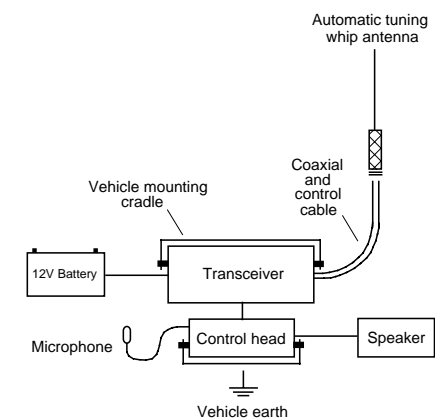

Figure 3.1: Typical vehicle installation

Mounting the transceiver



The transceiver must be mounted in a position that will not cause injury to occupants in the event of a motor vehicle accident.

Mount the transceiver and control head in a position that allows:

- **easy access to the control panel**
- **a free flow of air through the rear cooling fins.**

The transceiver mounting cradle is supplied with 6 metres of DC power cable. You must determine the mounting position to best suit your needs.

Step

Action

1. The cradle can support the transceiver from above or below permitting roof or floor mounting.

Secure the mounting cradle into position with the rotating cam catches to the front. Ensure there is sufficient space at the rear of the cradle to take the transceiver heat sink and connectors.

2. Align both cam catch slots with the T-section slides.

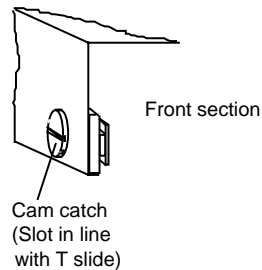

Step

Action

3. Insert the transceiver side rails into the T-section slides and push the transceiver fully into the cradle.
4. Apply gentle pressure to the front panel of the transceiver and lock into the cradle by turning the cam catches one quarter of a turn in either direction with a suitable tool or small coin.



Mounting the control head



The control head must be mounted in a position that will not cause injury to occupants in the event of a motor vehicle accident.

Mount the control head in a position that allows easy access to the control panel.

The control head must be connected to the transceiver before power is applied. Failure to do this may result in damage to the transceiver in the following ways:

- **the internal fuse blows and must be replaced**
- **the control head fails to operate. The power must be disconnected from the transceiver and then reconnected and switched on.**



Step

Action

1. Remove the two cradle screws and washers securing the mounting cradle to the control head.
2. Secure the mounting cradle into position. Ensure there is sufficient space at the rear of the cradle for the control cable.
3. Secure the control head to the mounting cradle with the two screws and washers.
4. Mount the transceiver (refer to *Mounting the transceiver* on page 3-2).
5. Connect the interface cable between the control head and transceiver. Ensure the cable connectors are securely fastened to the control head and the transceiver.

Notes: The extended control head is supplied with a cable approximately 6 m long. To enable correct installation, the cable has different connectors at each end.

If necessary, remove the cover from one connector to pass the cable through restricted openings.

If the cable is too long, gather the excess neatly at one point.



Mounting the antenna



The antenna is a critical element in any communication system. It cannot be overstressed that correct installation of the antenna is of prime importance to the operation of your Radiophone.

To obtain the best performance from your Radiophone, it is important to consider the following points when installing your antenna:

- physical location
- distance from the transceiver
- earthing.

Detailed and specific installation instructions are provided with the automatic tuning whip antenna. These instructions must be used to gain the best possible results from your antenna and transceiver.



Mounting the loudspeaker



The loudspeaker must be mounted in a position that will not cause injury to occupants in the event of a motor vehicle accident.

Step	Action
1.	Mount the speaker bracket securely to a suitable surface.
2.	Connect the appropriate cable between the loudspeaker and the control head or transceiver.



Power supply

Ensure that the power supply to operate your Radiophone is 12V DC—usually vehicle batteries.

All installations should be checked by a qualified technician before power is applied to the Radiophone.

The heavy duty six metre length of power cable has been selected to minimise the voltage drop between the battery and transceiver when in transmit mode. Installation using a smaller core cable size is not recommended.

All cables should be protected from sharp edges and mechanical abrasions.

It is recommended that a suitable cartridge fuse (32 Amp-accessory code 711) is fitted in the active wire, close to the battery, to protect the power cable from the possible risk of fire through damaged insulation coming in contact with the vehicle chassis. Normal glass in-line automotive fuses are not recommended. The transceiver is fitted with adequate internal protection.

Connect the power cable between the transceiver and the battery.

Note: In extended control installations where the power and control cables are long and follow a common path, keep the cables separate by a minimum of 200 mm. The cables can be brought together for short distances, for example, to pass through the same hole in a bulkhead. Failure to observe this warning will cause distortion of the transmitted audio signals.



Grounding

An adequate ground, or earth, is essential for satisfactory operation of the Radiophone.

A chassis ground or earth screw is provided on the rear panel of the transceiver. Install an earth cable between this screw and an earth point. Use copper braid or heavy duty cable.

The control head should also be earthed.





CODAN

4. Using the Radiophone

This section covers the basic steps necessary to operate your Radiophone.

It outlines how you use the control buttons to make various adjustments and settings, and includes transmitting and receiving calls.

Throughout this section all displays show examples of channel and frequency numbers. You must insert your selected channel and frequency numbers as appropriate.

Unless otherwise stated, it is assumed throughout this section that:

- 12V DC power is supplied to your Radiophone
- the Radiophone On/Off button is switched on.

Refer to *Switching the Radiophone on or off* on page 4-2.

Switching the Radiophone on or off

When you switch the Radiophone on, the display usually shows the last settings before the Radiophone was switched off. If your Radiophone has a personal identification number (PIN) allocated, then the display will request you to enter your PIN.

This section covers two methods of switching your Radiophone on or off:

- switching on or off without a PIN
- switching on or off with a PIN

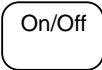
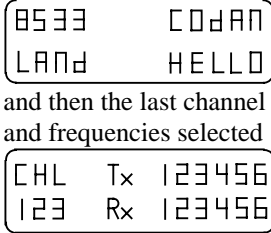
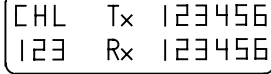
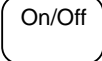

Switching on or off without a PIN

Step	Action...	Display shows...	Remarks...
1.	Ensure power is supplied to your Radiophone.		
2.	Press 	You will see this display for one second  and then the last channel and frequencies selected 	The Mute and Mode indicators and the LCD display illuminate. The Radiophone is turned on and automatically set to the last channel and volume settings used.
3.	To switch off, press 	The display and indicators go off.	The Radiophone is turned off.

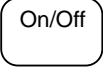
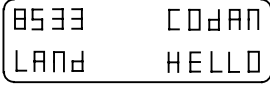

Switching on or off with a PIN

It is most important not to forget your PIN, otherwise you will never be able to switch on your Radiophone. If this happens, you will have to return the transceiver to Codan for them to delete the allocated number.

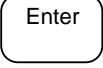
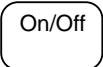
Step	Action...	Display shows...	Remarks...
1.	Ensure power is supplied to your Radiophone.		
2.	To switch on, press 	You will see this display for one second  and then this display 	The Mute and Mode indicators and the LCD display illuminate.
3.	Use the numeric buttons to enter your PIN.		You must enter the correct PIN, otherwise your Radiophone will never turn on to the operating mode.
4.	Press 	The display is automatically set to the last channel and volume settings used.	The Radiophone is turned on and can now be operated.
5.	To switch off, press 	The display and indicators go off.	The Radiophone is turned off.



The Radiophone display

The display provides you with visual indication of the selected channel numbers, and the transmit and receive frequencies. In addition, it shows you messages that will assist you when operating your Radiophone. A detailed description of all the messages can be found in section 12, *Display messages*.

The display– and button legends of the control head– are back-lit to give you the clearest view. If necessary, the brightness can be adjusted to suit your needs, refer to *Dimming the display indicators* on page 4-6.

This section explains what the option codes mean and how to reveal the option codes on the display.

The display contains two rows of information. Each row is split into three groups. What you see in each group depends on the Radiophone mode selected.

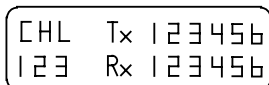

```

  CHL Tx 123456
  123 Rx 123456
  
```

Option codes

Code	Description
S	in the far left hand position indicates that selective call is enabled for this channel.
E	indicates that emergency calling has been enabled for this channel.
L	indicates the lower side band has been enabled for this channel.
U	indicates the upper side band has been enabled for this channel.
t1-4	indicates this channel has been programmed for tone calling. (Four tone pairs can be used, t1 to t4.)

Displaying the channel options

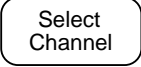
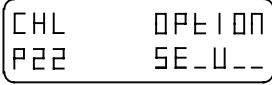

There are several options that you can select your Radiophone to use. The display button gives you the freedom to check the options that have been selected (enabled) at the time of purchase by viewing the option bar in the display.

Step	Action...	Display shows...	Remarks...
1.	Press 		<p>The option bar indicates the options enabled for the channel currently selected.</p> <p>There are six spaces in the option bar that contain either a code (see Option codes) or an underscore (_). An underscore indicates that no function has been enabled.</p>



Dimming the display and indicators

The backlit display and indicators are at maximum brightness when you switch the Radiophone on. This procedure explains how to reduce the brightness of the display and indicators.

Step	Action...	Display shows...	Remarks...
1.	Press  twice within one second		This reduces the brightness of the indicators and dims the display background lighting.
2.	To restore the brightness, press  again, twice within one second.		This restores both the display and indicators to their maximum brightness



Review the EPROM version and options

This facility allows you to review the EPROM version and some of the options fitted to your Radiophone.

This procedure is repeated in section 12, *Reviewing the EPROM program content*.

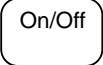
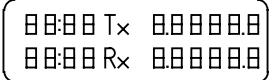
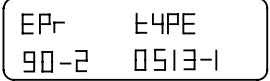
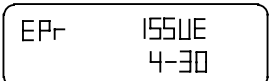
Step	Action...	Display shows...	Remarks...
1.	Ensure your Radiophone is switched on.		
2.	Press and hold down 	 at three second intervals the display changes and shows the following displays.	Displays lamp test: all segments must be on and all the indicators lit.
			This shows the Program (EPROM) type number (example 90-20513-1). Some indicator lamps will turn off.
			Program (EPROM) issue number. This is an example of EPROM issue 4.3.

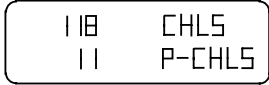
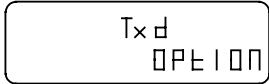
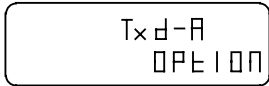
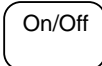

Step	Action...	Display shows...	Remarks...
2. cont.	The following displays indicate some of the options that may be fitted to your Radiophone.		<p>The top line shows the number of channels programmed by the factory or agent, this can be up to 501.</p> <p>The second line shows the number of channels programmed by the user, this can be up to 99 or 89 with the telephone mode enabled.</p>
			<p>d indicates that the Radiophone is inhibited from entering transmit frequencies from the front panel.</p>
			<p>A indicates that the Radiophone is programmed for use on the amateur bands (optional).</p>
3.	Release the 		This switches off your Radiophone.





Selecting channels

There are two methods of selecting channels:

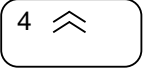

- Using the Channel Up or Down buttons—this method is preferable when you are changing to an adjacent channel
- Using the Select Channel button—since there may be up to 600 channels available, this method is preferable when you are changing channels over a large range.

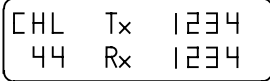
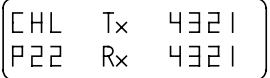
Using the Channel or buttons

Step	Action...	Display shows...	Remarks...
1.	Press either of the Channel buttons  or 	The channel number selected appears in the lower left hand corner of the display, and the transmit and receive frequencies to the right.  Channels you have programmed from the front panel will have either an F or P in front of the number. 	Pressing these buttons moves to the next higher or lower channel. Keep the button pressed to move quickly through the channels. For details on F and P channels, refer to sections 6 & 7 respectively.

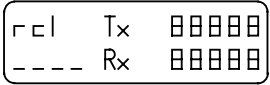
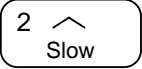

Using the select channel button

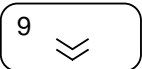
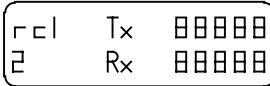
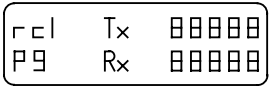
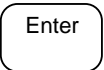
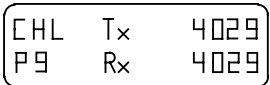



Step	Action...	Display shows...	Remarks...
1.	Press 		
2.	If the channel was installed by the factory, press  If the channel was installed by you, (F or P channels) press  and 	 	This is an example of how to recall channel 2. For details on F and P channels, refer to sections 6 & 7 respectively. This is an example of how to recall channel P9.
3.	Press 		The channel you selected will be recalled (in this case channel P9). If you enter an incorrect channel, the display shows the message 'NOT FOUND', and reverts to the next lowest programmed channel to the one you selected.
	Note: F numbers must always be selected as P numbers.		



Adjusting the volume

This procedure tells you how to adjust the volume. When the mute is on, pressing any of the volume control buttons opens the mute for approximately one second. This allows you to hear the background noise, thus assisting you to select the correct level.





When you switch your Radiophone on, the volume level is at the last used setting.

Step	Action...	Display shows...	Remarks...
1.	Press either of the Volume buttons  or 	The display does not change.	The  button increases the volume. The  button decreases the volume. You will hear a "pip" when the volume control has reached its operating limit.

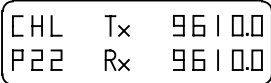

Using the clarifier

The clarifier buttons raise or lower the frequency in steps of 10 Hz. This allows you to fine tune the Radiophone to obtain the best clarity for received voice calls.

Step	Action...	Display shows...	Remarks...
1.	Press either of the Clarifier buttons  or 		Alternate between the  and  buttons to obtain the best clarity. You will hear a "pip" when the clarifier control has reached its operating limit. Note: the clarifier resets to the mid range when you change channels, or switch off.



Using the mute controls

There are two mute controls that inhibit background noise until a signal is received:



- Voice Mute—this function inhibits background noise until a voice signal appears.
- S'Call Mute—this function inhibits background noise until your transceiver has been selectively called.

Voice mute

Step	Action...	Display shows...	Remarks...
1.	To switch on and off press 	The display does not change.	The indicator is lit when this option is selected. Inhibits background noise until a voice call is received.





Selective call mute

Step	Action...	Display shows...	Remarks...
1.	To switch on press  to switch off press 	The display does not change.	The indicator is lit when this option is selected. Inhibits background noise until a selective call is received.



Tuning the antenna

Before using the selected channel, the antenna must be tuned to the transmission frequency.

Step	Action...	Display shows...	Remarks...
1.	Select the required channel.		Refer to page 4-9, <i>Selecting channels</i> .
2.	Press 	<p>If tuning was successful</p>  <p>If tuning was unsuccessful</p> 	<p>The Tx indicator will be lit during this procedure.</p> <p>You will hear 'pips' while the antenna is tuning (this can take between 20 and 30 seconds).</p> <p>Once tuned successfully you will hear two high pitched 'pips'.</p> <p>If tuning is unsuccessful you will hear two low pitched tones. For further information, refer to the antenna handbook.</p>



Receiver tuning mode



Your Radiophone can be tuned to receive frequencies in the range 0.25 MHz to 30 MHz.

Note: Due to internally generated signals, it will be difficult to receive on and near frequencies 6599, 9998, 13199, 19799, 19995 and 26399 kHz.





While you are in receiver tuning mode you cannot receive selective calls or tone calls.

Note: The Tune button should be pressed to improve reception. This is also recommended for transmit inhibit channels.

This procedure covers the two methods of changing the Radiophone frequency, and how to store a receive only frequency:

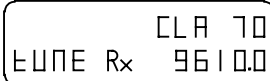
- using the Receiver Tuning  or  buttons—this method is preferable for small changes in frequency.
- selecting the desired frequency—this method is preferable for large changes in frequency
- storing a tuned receive only frequency.

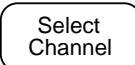

Using the Receiver Tuning or buttons

Step	Action...	Display shows...	Remarks...
1.	Press and hold any Receiver Tuning button.	<p>The display scrolls through the numbers until you release the button.</p> 	<p>Use the Fast buttons for coarse tuning (1 kHz steps) and the Slow buttons for medium tuning (100 Hz steps).</p> <p>For fine tuning, the Clarifier  and  buttons can be used to make final adjustment in 10 Hz steps.</p>
2.	<p>There are three ways to exit this mode, either press the Channel  or  buttons, the</p>  <p>button, or the PTT button on the microphone.</p>		



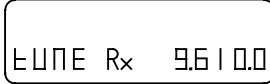

Selecting the desired frequency

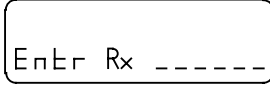
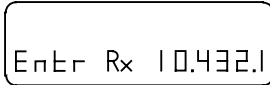
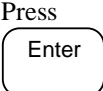
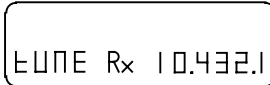
This procedure allows you to select the frequency you desire, and therefore save time. Once you have selected a frequency you have the option to store the frequency as a P-channel or exit this facility.

Step	Action...	Display shows...	Remarks...
1.	Press any Receiver Tuning button.		The display shows the last selected channel.
2.	Press 		Your next action must start within 60 seconds, otherwise you will have to repeat this procedure.
3.	Enter the frequency number using the numeric buttons.		The decimal point is automatically inserted by the transceiver. The example shows the display reading if you typed in 104321.
4.	Press  If required, you can fine tune reception by using the Receiver Tuning buttons.		The Radiophone now receives this frequency. Note: after pressing the Enter button, the MHz decimal point disappears for frequencies below 10 MHz.





Step	Action...	Display shows...	Remarks...
5.	If you wish to store this selection as a P-channel, refer to the procedure <i>Storing a tuned receive only frequency</i> on page 4-19.		
6.	There are three ways to exit this mode, either press the Channel  or  buttons, the  button, or the PTT button on the microphone.		



Storing a tuned receive only frequency

You can store a tuned receive only frequency as a personal channel number in the range P1 to P99. This frequency can then be selected as outlined on page 4-9, *Selecting channels*.

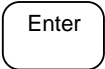
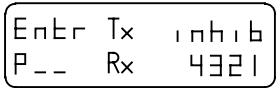
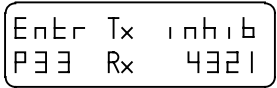
This procedure can only take place if your Radiophone is in the tune receive only mode, as outlined on page 4-17 *Selecting the desired frequency*

Step	Action...	Display shows...	Remarks...
1.	Press the Enter button twice in rapid succession. 		The display will be different if you only press the Enter button once.
2.	Use the numeric buttons to enter a channel number you have selected between 1 and 99.		The P is automatically inserted. The example is given for number P33.
3.	Press 		The frequency is now stored as channel P33 and your Radiophone has returned to the normal operating mode.



Changing the operating mode (USB - LSB)

Your Radiophone has the facility to operate in either Upper Side Band (USB) or Lower Side Band (LSB) mode. When receiving broadcast stations such as the BBC or Radio Australia, changing between USB and LSB may reduce interference.

Unless otherwise advised, your Radiophone is normally programmed to operate in the USB mode.

Operation of the USB/LSB button applies when the Radiophone is in the *Receiver tuning mode*, refer to page 4-15.

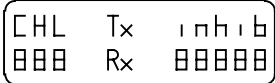
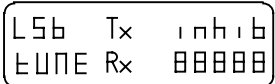
Step	Action...	Display shows...	Remarks...
1.	Press the mode button to switch between USB or LSB.	<p>In the USB mode the display shows</p>  <p>In the LSB mode the display shows</p> 	This is just an example to show that the display indicates LSb when in the lower side band mode.



Transmitting

It is important when transmitting to use the microphone to its best advantage. By following the notes under *Using the microphone* you will obtain the best transmitting results. This section covers two topics:

- using the microphone
- transmitting a message.

Using the microphone

To connect the microphone to the control head; push the microphone plug gently into the microphone socket and fasten the locking ring finger tight, do not over tighten.

Please observe the following notes when using the microphone.

- Hold the microphone side-on and close to your mouth.
- Press and hold down the PTT (press to talk) button.
- When starting a transmission, always state the call sign of the person you are addressing and then your own call sign.
- Speak clearly at normal volume and rate.
- Do not use abusive language, remember others may be listening to your conversation and it can offend.
- Use the word 'over' to indicate you have finished speaking and release the PTT button.
- The Radiophone has a 'time out' facility that stops the transmission after a pre-set period. This facility prevents problems occurring if you have jammed the PTT button down. The time out period can be adjusted to suit your requirements; refer to section 11, *Changing the set-up options*.

Transmitting a message

Step	Action...	Display shows...	Remarks...												
1.	Select a channel for transmission.	The display shows the channel number and the transmit (Tx), and receive (Rx) frequencies.	Refer to page 4-9, <i>Selecting channels</i> .												
2.	Check the display to see if the channel transmit frequency has been enabled.	<div style="border: 1px solid black; padding: 5px; display: inline-block;"> <table style="border-collapse: collapse;"> <tr> <td style="padding: 2px 5px;">CHL</td> <td style="padding: 2px 5px;">Tx</td> <td style="padding: 2px 5px;">4321</td> </tr> <tr> <td style="padding: 2px 5px;">P22</td> <td style="padding: 2px 5px;">Rx</td> <td style="padding: 2px 5px;">4321</td> </tr> </table> </div> <p>If the display shows 'inhib' then the channel frequency is for receive only purposes.</p> <div style="border: 1px solid black; padding: 5px; display: inline-block;"> <table style="border-collapse: collapse;"> <tr> <td style="padding: 2px 5px;">CHL</td> <td style="padding: 2px 5px;">Tx</td> <td style="padding: 2px 5px;">i n h i b</td> </tr> <tr> <td style="padding: 2px 5px;">P15</td> <td style="padding: 2px 5px;">Rx</td> <td style="padding: 2px 5px;">3600</td> </tr> </table> </div>	CHL	Tx	4321	P22	Rx	4321	CHL	Tx	i n h i b	P15	Rx	3600	<p>If the channel has been enabled, continue with step 3.</p> <p>If not and the display shows 'inhib' then you will have to select another channel on which to transmit.</p>
CHL	Tx	4321													
P22	Rx	4321													
CHL	Tx	i n h i b													
P15	Rx	3600													
3.	Tune the antenna.		Refer to page 4-14, <i>Tuning the antenna</i> .												
4.	Listen and check that the channel if from traffic.														



Step	Action...	Display shows...	Remarks...
5.	Press the PTT button on the microphone and commence talking. Transmit your message following the notes outlined in <i>Using the microphone</i> on page 4-21.		The Tx indicator flashes during transmission.



5. Using selective call

Selective call allows you to call Radiophones or equivalent transceivers. This can be best likened to a normal telephone system where the called station has a unique calling address or number. However, the operator can also call a group of stations if desired.

Each Radiophone has its own identification number. The identification number is a four digit code that is self programmed into the Radiophone using the control head front panel buttons.

The selective call feature operates by the transmission and reception of coded signals. These signals contain the identification number of the Radiophone or transceiver being called (the called address) and the number of your Radiophone making the call (the self-identification).

All displays in this section show examples of channel and frequency numbers. You must insert your selected channel and frequency numbers.

Selective call terms

The following terms are used in this section.

This term...	Means...
Called address	The four digit identification number of the Radiophone being called.
Beacon call	A call used to check signal conditions.
Decoding	Receiving and translating the encoded message.
Encode	The translation of the identification number and instructions into a coded message for transmission.
Group call	A call to all Radiophones within a selected group. For example, a call using the identification address 0200 (group call) will be received by all Radiophones whose identification address falls in the two hundred digit range (0201 to 0299).
Preamble	Part of the coded selective call message structure which is transmitted when you press the Selective Call button. The message contains the preamble tone which precedes the called address and the self-identification address codes.
Program	Setting the identification addresses into the Radiophone.



This term...	Means...
Revertive Signal	A signal automatically transmitted back from the receiving Radiophone to indicate message received and decoded satisfactorily. This signal does not apply to group calls.
Selective beacon call	A call used to check signal conditions to a selected station.
Self-identification	The four digit identification number of the calling Radiophone.
Station	A term used for the location of a Radiophone or transceiver.
Selective call encode/decode	The Radiophone can transmit and receive a selective call.



Setting up selective call

There are several features that need to be set up before selective call is used:

- the preamble time period
- the called address
- the self-identification address
- the beacon on or off.

You may cancel the procedure at any time by turning the Radiophone off (press the On/Off button). Turning the Radiophone off stores any changes you made to the features.

Once you have commenced this procedure, if no action is required you can skip through all the features by repeatedly pressing the Selective Call button.

Notes: A long preamble is required when scanning selective calls.

The reason for a long preamble is that during scanning, the preamble has to be present throughout the time it takes to scan all eight selective call channels.



Do not use identification addresses ending in '00' and '99' as they are used for the group call and beacon facilities.



You must always enter information within 60 seconds of pressing the Enter button, otherwise the Radiophone reverts back to the normal mode.

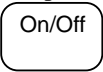

Step	Action...	Display shows...	Remarks...
------	-----------	------------------	------------

Setting the pre-amble time period

1. Ensure your Radiophone is switched off.

2. Hold down  and press .  Hold the Selective Call button down for approximately three seconds. This turns the Radiophone on and into the preamble set-up mode.

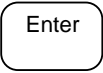
3. Press any of the numeric buttons to set the preamble length.  Pressing any of the numeric buttons alternates between a long or short preamble.
or 

4. Press .  Once enter has been pressed, the pre-amble time has been set and can only be changed by repeating this procedure.



Step	Action...	Display shows...	Remarks...
------	-----------	------------------	------------

Setting the fixed called address

There are two ways of entering the called address:

- a) as below, which is fixed and cannot be changed easily
- b) by the method used on page 5.14, *Transmitting a selective call* (Open access selective call) which allows the address to be entered from the front panel of the control head and is easy to change to call another Radiophone or transceiver.

Note: by setting a fixed called address the normal function of Selective Call will change. If a fixed call address has been set, pressing Selective Call will automatically send the programmed address. Open access selective calling is disabled.

5. Use the numeric buttons to enter the called address number.
- | | |
|------|------|
| SEL | CALL |
| Addr | 4835 |
- You can override an existing address by entering a new number.

To delete an address, enter four zeros.

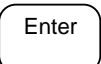
6. Press 
- | | |
|------|------|
| SEL | SELF |
| Addr | ---- |
- Once Enter has been pressed, the called address has been set and can only be changed by repeating this procedure.

The next step must be completed within 60 seconds.



Step	Action...	Display shows...	Remarks...
------	-----------	------------------	------------

Setting the self-identification address

7. Use the numeric buttons to enter the self-identification address number.



You can override an existing address by entering a new number.

To delete an address, enter four zeros.

8. Press



Once Enter has been pressed, the self identification address has been set and can only be changed by repeating this procedure.

The next step must be completed within 60 seconds.

Enabling the beacon mode

9. Press any of the numeric buttons to switch the beacon on or off.

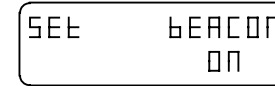

or



Repeatedly pressing any of the numeric buttons switches the beacon on and off.

For more information on this feature, refer to page 5-25, *Using the beacon feature*.



Step	Action...	Display shows...	Remarks...
------	-----------	------------------	------------

10. Press 

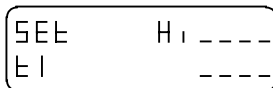

SEE HI ----
EI ----

This sets the new beacon setting and moves to the next feature (tone calling).

For more information on tone calling, refer to section 8, *Using tone call*.

Setting tone calls

11. This procedure is not required at this time.

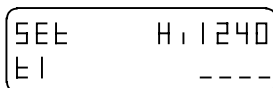

SEE HI 1240
EI ----

This procedure is covered in detail in section 8, *Setting up tone call*.

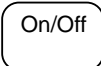

12. Press 

This turns your Radiophone off and registers all the selective call settings you have just made.



Checking if a channel is enabled for selective call

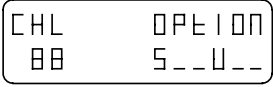

A channel must be enabled for the selective call facility to operate. If the channel you wish to use has not been enabled, refer to the procedure *Enabling a channel for selective call* on page 5-12.

Step	Action...	Display shows...	Remarks...
1.	Press and hold 		An S in the left hand position of the options bar indicates that the channel is enabled for selective calling.
2.	Release 	The display will return to its original display in approximately one second.	

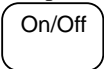

Selective call mute enable or inhibit

This facility enables or inhibits the operation of the S'Call Mute button. When S'Call Mute is inhibited you cannot operate selective call mute.

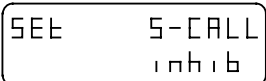
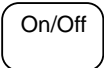
Step	Action...	Display shows...	Remarks...
1.	Turn the Radiophone off and move the control head panel link from position E to position 1.	No display.	Before moving the link, note its original position. Refer to section 11, <i>Changing the position of the control head link.</i>
2.	Hold down  and press 	Hold the S'Call Mute button down until the display shows 	Repeatedly pressing S'Call Mute will switch between ENABLE and inhib (inhibit).
3.	Press 		Stop at the selection you require.
4.	Press 	No display.	The Radiophone is now switched off.



Step	Action...	Display shows...	Remarks...
------	-----------	------------------	------------

5. Return the control head link to its original position (E).

Refer to section 11,
*Changing the position of
the control head link.*

6. Replace the cover before switching on your Radiophone.





Enabling a channel for selective call



This procedure explains how to enable an existing programmed channel for selective calling. To achieve this you are required to copy the existing programmed channel into the P-channel program, as outlined below.

This procedure is similar to *Enabling a channel for tone call* in section 8.

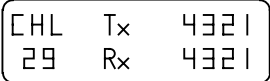
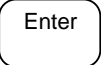
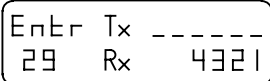
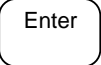
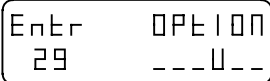
The displays in this section will vary depending on the channel you select.

Step	Action...	Display shows...	Remarks...
1.	Use the Select Channel or Channel  and  buttons to find the channel you wish to enable.	 <p>An example for channel 29.</p>	Refer to section 4, <i>Selecting channels</i> .
2.	Press 		You will hear a 'pip'.
3.	Press 		You will hear a 'pip'. The display shows the individual options for the chosen channel.



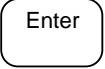
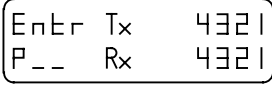
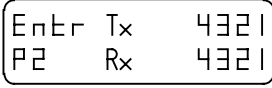
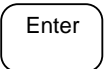
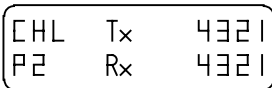
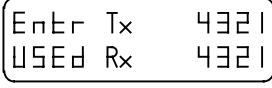

Step	Action...	Display shows...	Remarks...
4.	Press  Repeat this action until an S appears in the left hand position of the options bar.		You will hear a 'pip'.
5.	Press 		You will hear a 'pip'.
6.	Use the numeric buttons to enter the 'P' channel number you wish to use.		You will notice that the display automatically inserts a 'P' to the number.
7.	Press 	 If the channel is already used the display shows 	
8.	If the channel is already used, you can either enter another number or press Enter again to override the existing one.	The display reverts back to normal.	The information will either be stored under an existing channel number, or you will have created a new one.



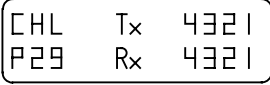

Transmitting a selective call



For selective call to operate you must have your self-identification number programmed, refer to *Setting the self-identification address* on page 5-7.

Step	Action...	Display shows...	Remarks...
1.	Select the required channel.		<p>Ensure the channel is enabled for selective call. Press the Display button to view the enabled options.</p> <p>If you need to enable the channel, refer to <i>Enabling a channel for selective call</i> on page 5-12.</p>
2.	Press  to turn the Voice Mute to the off position.	The display does not change.	The indicator will go out, and you will hear background noise.
3.	Check that the channel is free from traffic. If the channel is busy; wait until the channel is free, or try another channel.	The display does not change.	You will need to listen for approximately 10 seconds to ensure the channel is free.



Step	Action...	Display shows...	Remarks...								
4.	<p>If your Radiophone has the fixed called address, press twice in succession</p> <p style="text-align: center;">  </p>	<div style="border: 1px solid black; padding: 5px; display: inline-block;"> <table style="border-collapse: collapse;"> <tr> <td style="padding: 2px 10px;">CHL</td> <td style="padding: 2px 10px;">CALL</td> </tr> <tr> <td style="padding: 2px 10px;">P29</td> <td style="padding: 2px 10px;">1374</td> </tr> </table> </div> <p>This is an example of the called address identification number 1374.</p> <p>If the called address had been programmed, as described on page 5-6, then the permanent address will be displayed.</p>	CHL	CALL	P29	1374	<p>The Tx indicator will be lit and you will hear a 'warbling' sound for approximately 10 seconds.</p> <p>Proceed to step 8.</p>				
CHL	CALL										
P29	1374										
5.	<p>If your Radiophone does not have the fixed called address programmed, press</p> <p style="text-align: center;">  </p>	<div style="border: 1px solid black; padding: 5px; display: inline-block;"> <table style="border-collapse: collapse;"> <tr> <td style="padding: 2px 10px;">CHL</td> <td style="padding: 2px 10px;">CALL</td> </tr> <tr> <td style="padding: 2px 10px;">P29</td> <td style="padding: 2px 10px;">1374</td> </tr> </table> </div> <div style="border: 1px solid black; padding: 5px; display: inline-block;"> <table style="border-collapse: collapse;"> <tr> <td style="padding: 2px 10px;">CHL</td> <td style="padding: 2px 10px;">CALL</td> </tr> <tr> <td style="padding: 2px 10px;">P29</td> <td style="padding: 2px 10px;">----</td> </tr> </table> </div>	CHL	CALL	P29	1374	CHL	CALL	P29	----	<p>If the display shows the correct address, proceed to step 7.</p> <p>If no address, or an incorrect address is shown, continue with step 6.</p>
CHL	CALL										
P29	1374										
CHL	CALL										
P29	----										
6.	<p>Use the numeric buttons to enter the required selective call address number.</p>	<div style="border: 1px solid black; padding: 5px; display: inline-block;"> <table style="border-collapse: collapse;"> <tr> <td style="padding: 2px 10px;">CHL</td> <td style="padding: 2px 10px;">CALL</td> </tr> <tr> <td style="padding: 2px 10px;">P29</td> <td style="padding: 2px 10px;">1374</td> </tr> </table> </div>	CHL	CALL	P29	1374					
CHL	CALL										
P29	1374										

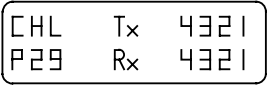

Step	Action...	Display shows...	Remarks...
7.	Press 		You will hear a 'warbling' sound for approximately 10 seconds.
8.	If the call was successfully received and decoded, within 25 seconds you will hear a revertive signal comprising of a number of short tones.		You will hear no sound if it was a group call. Normal transmission can now commence.



Receiving a selective call

Your Radiophone automatically completes the following event when receiving a selective call.

Step	Action...	Display shows...	Remarks...
1.	No action, the Radiophone automatically completes this event.	 <p>When you receive a call the display changes to show you the self-identification address of the calling station.</p>	<p>When you receive a call, tones will be heard on the loudspeaker.</p> <p>You will hear a series of three telephone rings for selective calls, and 16 short 'beeps' for group calls.</p>

Notes: On receipt of a call you have two options:

- either answer it immediately, refer to *Answering a received call* on page 5-19
- let the Radiophone automatically store the callers self identification number in memory to await your reply, refer to *Returning a received call-general* on page 5-20.

If your Radiophone was unattended at the time the selective call was received, the callers self identification number is stored in memory for you to review at a later time. Refer to *Reviewing the list of received calls in memory* on page 5-21.

If you do not answer the call immediately, once the call is stored in memory your Radiophone will continue to give out 'pips' every four seconds to indicate that a call has been received. If you wish to silence these 'pips', yet still retain the display, press the Select Channel button.

If you only wish to receive selective calls, ensure the S'Call Mute button is operated and the indicator lit.



Notes
cont.

If the microphone PTT button is not pressed before the end of the tones:

- the called display will remain on to indicate that a call was received
- a 'pip' will be heard every four seconds
- the external alarm relay contacts will close for approximately two minutes (refer to page 5-31, *Using the external alarm feature*).



Answering a received call





This procedure is used when you want to begin talking on a call that has just been received on your Radiophone which is still producing the ringing tone.

Step	Action...	Display shows...	Remarks...
1.	The display shows the channel number and the identification address of the caller.		
2.	Press the microphone PTT button twice in succession.	The display either reverts back to the normal display or shows the details of the next (if any) unanswered calls.	<p>The first press of the PTT button cancels the call and the S'Call Mute.</p> <p>The second press of the PTT button allows you to transmit to the caller.</p> <p>Proceed to use the Radiophone in the normal way..</p>

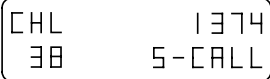

Returning a received call—general

This procedure is used when you want to return a call that has been stored in the memory stack.

Step	Action...	Display shows...	Remarks...
1.	Select the call you wish to return. If necessary, tune the antenna.	 <p>The display shows the channel number and the identification address of the caller.</p>	Refer to <i>Reviewing the list of received calls in memory</i> on page 5-21.
2.	Press 		The call details are now deleted from memory, but ready to transmit.
3.	Check that the channel is free from traffic, then press 	The display shows the details of the next unanswered call.	<p>The Radiophone sends the selective call and the transmit indicator will light.</p> <p>If the call is answered, proceed to use the Radiophone in the normal way.</p>



Reviewing the list of received calls in memory

Your Radiophone is able to record up to 10 calls in memory from various stations. These may be on different channels if your Radiophone is on scan mode. These calls are recorded in a memory stack awaiting your review. If a station calls more than once on the same channel, your Radiophone only records one of the calls. If more than 10 calls are made to your Radiophone, the first call stored in memory is deleted to make room for the latest call.

Ensure your Radiophone is not in the scan mode before commencing this procedure.



A permanent or brief loss of power to your Radiophone will delete information stored in memory . Ensure you record or use all the information stored in the memory stack before switching off the Radiophone.

Notes: If the Radiophone power is lost momentarily (such as during starting the vehicle engine), the call memory is retained but the number is lost.

Switching the Radiophone off using the On/Off button deletes all calls stored in the memory stack.



There are two methods of reviewing the list of received calls held in the memory:

- reviewing calls held in memory
- recalling calls held in memory.



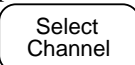

Reviewing calls held in memory

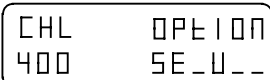
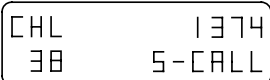
This procedure allows you to review all calls held in the memory in the order received. Ensure the Radiophone is not in scan mode when reviewing the list of selective calls received.

If no calls have been made to your Radiophone, the display will continue to show both the channel and frequency numbers.

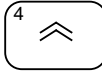
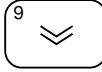
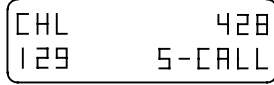
Step	Action...	Display shows...	Remarks...
1.	No action, this is what you will see on the display of your Radiophone. If scanning – and not on the channel that called – the display will show CALd.		The last call recorded will be shown in the display.
2.	To view the calls held in memory, press and hold  until the display shows . . . then press within one second  again and the display shows . . .	 	The first station to call will be displayed first. The display shows the callers identification code (1374) and the channel used (38).



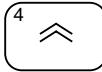
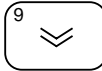



Step	Action...	Display shows...	Remarks...
3.	Press either  or 		Pressing  will change the display to show the next call, and  will reverse the order viewed. The identification address and corresponding channel number will change for each caller.
4.	If you wish to return a call, refer to <i>Returning a received call—general</i> on page 5-20.		
5.	To delete a call, press the PTT button on the microphone.	The display will show the next caller's details.	When you press the PTT button, the identification number in the display is deleted from memory. You can then select, call or clear the remainder of the calls from memory.
6.	Press  and then press either  or 	The display shows the standard display.	This returns the Radiophone to normal operation.

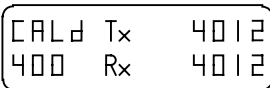

Recalling calls held in memory

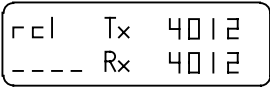
Ensure the Radiophone is not in scan mode when recalling a selective call held in memory.

Step	Action...	Display shows...	Remarks...
1.	No action.		
2.	Press  and then 	 	
3.	Check that the channel is free from traffic, then press  twice within one second.	The display shows the details of the next unanswered call.	The Radiophone sends the selective call.
4.	Once the recalled channel has been cleared, to recall other calls held in memory they have to be brought forward by repeating steps 2 and 3.		



Using the beacon feature

The beacon facility is used to check signal conditions between two Radiophones fitted with selective call.

The beacon facility has two modes of operation:

- selective beacon mode
- base station (99) beacon mode.

Selective beacon mode

With the beacon facility enabled on a Radiophone, it will transmit a beacon signal on receipt of a selective beacon call from another Radiophone. Refer to the *Selective beacon mode* procedure on page 5-27.

Both Radiophones must be on the same channel, or the receiver of the selective beacon call must be scanning through the same channel.

(99) beacon mode

The 99 beacon mode is recommended for use in base station applications and for those transceivers that may have operating selective call but do not have the beacon mode facility.

With a base station enabled for beacon mode, it will transmit a beacon signal on receipt of a selective call ending in 99. Refer to the *(99) beacon mode* procedure on page 5-29.

The thousand and hundred digits of the address must be the same for both the beacon transmitting and receiving stations.

If mobile Radiophones have the beacon enabled, the first two digits of each mobile Radiophone's self-identification address should be set to a different number so that they do not all transmit a beacon response together.



General information for both modes of operation

The beacon signal consists of four long tones.

Self-identification addresses ending in 99 should be avoided as these will cause confusion.



No alarm or call is recorded at the receiving Radiophone, only the Tx indicator flashes.

If the receiving Radiophone is in scan mode, the scan sequence recommences immediately.



Normal selective call operation is not affected.



Selective beacon mode

Step	Action...	Display shows...	Remarks...
1.	Ensure your Radiophone is switched on.	The last channel selected.	
2.	Select the required test channel and tune the antenna.		Refer to section 4, <i>Selecting channels</i> .
3.	Press 		When this button is pressed, the S'Call Mute is automatically switched off.
4.	Use the numeric buttons to enter the required selective call address number.		This allows you to send a selective call to a station whose address number is 1374.





Step	Action...	Display shows...	Remarks...
5.	<p>Check that the channel is free from traffic, then press</p>  <p>(beacon call button)</p>	 <p>Immediately the call is received, the display shows the last channel and transmit & receive frequencies used.</p>	<p>The transmit indicator will be lit and you will hear a warbling sound for approximately 10 seconds. If the call is successfully decoded you will hear four long revertive tones.</p> <p>You can check these tones for signal strength and compare them with signal strengths from other channels. Select the channel giving the best return signal strength.</p>

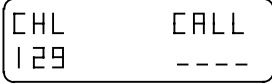
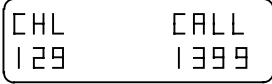

(99) beacon mode

Step	Action...	Display shows...	Remarks...
1.	Ensure your Radiophone is switched on.	The last channel selected.	
2.	Select the required test channel and tune the antenna.		Refer to section 4, <i>Selecting channels</i> .
3.	Press 		When this button is pressed, the S'Call Mute is automatically switched off.
4.	Use the numeric buttons to enter the required selective call number. Use the first two digits of the stations self identification number and ensure the last two are 99.		This will send a signal to the base station enabled for beacon call, whose four digit self ident address begins with 13.



Step	Action...	Display shows...	Remarks...
5.	<p>Check that the channel is free from traffic, then press</p>  <p>(beacon call button)</p>	 <p>Immediately the call is received, the display shows the last channel and transmit & receive frequencies used.</p>	<p>The transmit indicator will be lit and you will hear a warbling sound for approximately 10 seconds. If the call is successfully decoded you will hear four long reveritive tones.</p> <p>You can check these tones for signal strength and compare them with signal strengths from other channels.</p> <p>Select the channel giving the best return signal strength.</p>



Using the external alarm feature

An external alarm facility is made available through the external alarm socket on the rear panel (refer to figure 2.2).

A pair of relay contacts are wired to the socket, which close for two minutes when your Radiophone receives a selective call. The relay contacts can be used to operate an alarm bell or buzzer.

- Relay contact rating: 50V DC - 1 Amp
- Plug connections: pins 2 and 3.

Further details on the socket can be found in section 13.



These contacts must not be used to switch voltages greater than 50V, or loads that draw more than 1 Amp.





Testing the selective call functions

This is a special test mode which will not be required for normal operations.

In this mode, the Radiophone decodes all selective call signals, and displays the address to which it was sent and the self identification of the calling station.

No called alarms or revertives are generated. (A revertive is a signal transmitted back from the receiving Radiophone to indicate message received and decoded satisfactorily.)

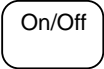
Ensure your Radiophone is switched off before entering this mode.

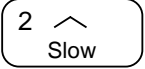
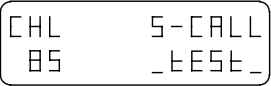
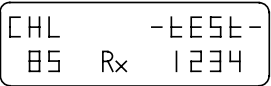
Step	Action...	Display shows...	Remarks...
1.	Press and hold  and press 		Do not hold down the On/Off button, just the Slow button for approximately five seconds.
2.	Press  within 10 seconds of releasing the  button.		
3.	No action. After approximately five seconds the display changes.		The display stays the same until a selective call is received.

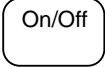

Step	Action...	Display shows...	Remarks...
4.	No action.		When a selective call is received, the display shows the called station identification address and the self identification address.
5.	To exit this mode, press 		You must switch your Radiophone off and on again to clear this mode.



Using selective call



CODAN

6. Using the receiver in scan mode

In the receiver scan mode your Radiophone is able to listen into selected channels for transmitted signals. Once a signal has been detected, the Radiophone holds that channel for a pre-selected time before continuing with the scan. This is determined at set-up.

In normal operating conditions, a maximum of 15 channels can be programmed to be scanned in sequence for audio (voice) signals. A maximum of 8 selective call channels can also be included but must be programmed within the first eight entries.

All displays in this section show examples of channel and frequency numbers. You must insert your selected channel and frequency numbers.



Scan mode terms

The following abbreviations are shown in the display.





- F Frequency
- L Lower side band
- LU Lower and upper side band
- U Upper side band





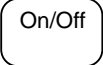

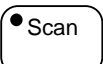
Setting up the scan mode

The scan program allows your Radiophone to scan a selected number of frequencies. Your Radiophone also has the option to run in normal or Auto-scan mode. The Auto-scan mode automatically puts the Radiophone back into scan after five minutes of inactivity (such as no channel change, PTT, tune etc.). These scan facilities have two options:

- Enabled—scan programs can be entered and deleted from the control head front panel.
- Inhibit—scan programs cannot be entered or deleted from the control head front panel.

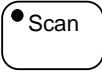
Step	Action...	Display shows...	Remarks...
1.	Ensure your Radiophone is switched off.		
2.	Hold down  and press 	Hold down the Scan button until the display shows 	This turns the Radiophone on, and into the scan set-up mode.
3.	Press 		Each press of the Scan button scrolls to the next option. If this is the option you want, go to step 7.

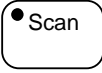

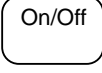



Step	Action...	Display shows...	Remarks...
4.	Press 		Switches to Auto option. If this is the option you want, go to step 7.
5.	Press  Pressing the Scan button again returns you to the display in step 2.		Switches from inhib to ENABLE.
Note: If you select automatic scanning, you now have the option of selecting Selective Call Mute to be enabled as soon as you enter the automatic scan mode. If you wish to select this option then continue with step 6, if not, go to step 7			
6.	Press 	The display does not change.	The indicator will be lit. You have now selected selective call mute to be enabled as soon as you enter the automatic scan mode.
7.	Press 	No display.	Your selection has been made and the Radiophone is now switched off.



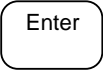
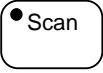
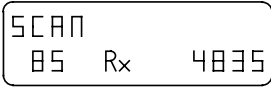

Programming the channels to be scanned

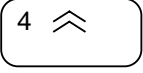
In normal operating conditions, a maximum of 15 channels can be programmed to be scanned in sequence for audio (voice) signals. Channels required to operate on a selective call must be programmed within the first eight entries.

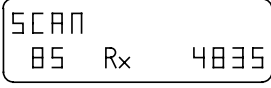
Ensure your Radiophone is switched on and scan program has been enabled.

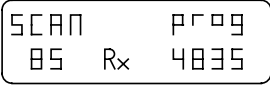

Step	Action...	Display shows...	Remarks...
1.	Press  and then  within one second.		The Scan button indicator flashes. Any previous channels programmed to be scanned will be erased.
2.	Select the required mode Press 	The display will indicate LSB if the lower side band has been selected.	You can only transmit and receive in the LSB mode if option LU is fitted.
3.	Select the relevant channel Press  or 		Refer to section 4, <i>Selecting channels</i> . Channels required to operate on selective call must be enabled. Refer to section 5, <i>Enabling a channel for selective call</i> .

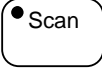

Step	Action...	Display shows...	Remarks...
4.	Press 		The channel is programmed for scanning. Repeat this procedure until all channels you want to scan have been programmed.
5.	Press  and then  within one second.		The channels you have programmed are now registered within the transceiver.

Notes: If an error is made, the programming mode must be switched off (follow step 5), and the procedure repeated.

If you try to program more than 15 entries, you will hear a single low-pitched tone and the error message 'scan full' displays.

The channel entries can be reviewed while in the scan programming mode. Use the channel  and  buttons to scroll through the channels. Any channel in the scan program is indicated by 'prog' on the display (as shown in step 4 above).

The scan program can be inhibited, refer to *Setting up the scan mode* on page 6-3.



Receiving in scan mode

This procedure covers three topics when receiving in scan mode. Ensure your Radiophone is switched on before proceeding with any of the following:

- start scanning
- stop scanning
- changing the scan mode.

Start scanning

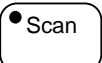
Step	Action...	Display shows...	Remarks...
1.	Press 	The display shows details of each channel as it is scanned.	The Scan button indicator will be lit during scanning.

Notes: You cannot transmit while the Radiophone is in the scan mode. If you attempt to transmit, you will hear a single 'pip' and the error message 'No Ptt Error' will be displayed.

If you need to transmit, you must stop the scanning operation.

Stop scanning

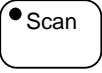
Step	Action...	Display shows...	Remarks...
1.	Press  or press the microphone PTT button twice in succession.	The display shows the last channel scanned.	The Scan button indicator is off.

Note: If you only press the PTT button once, the display shows 'NO PTT Error'

Changing the scan mode



There are three scan mode options available to you which can be selected by repeatedly pressing the Voice Mute button. Your Radiophone must be in the scan mode to complete this operation (refer to *Receiving in scan mode* on page 6-7).

- Pause scanning. Scanning stops for five seconds when an audio signal is detected.
- Hold scanning. Scanning stops when an audio signal is detected, and continues only when the signal ceases.
- Continuous scanning. Each channel is monitored for one second; scanning continues regardless of any audio signals being detected.

Note: scan modes operate for both voice and selective call reception.

Step	Action...	Display shows...	Remarks...
1.	Ensure the Radiophone is in the Scan mode.	The display shows the frequencies as they are scanned.	The Scan button indicator will be lit in the Scan mode. Refer to <i>Receiving in scan mode</i> on page 6-7.
2.	Pause scanning Press once 		You will hear a single 'pip' and the Voice Mute indicator will be lit. If you want <i>Hold scanning</i> , go to step 3. To exit this mode go to step 5.

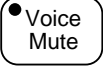

Step	Action...	Display shows...	Remarks...
3.	Hold scanning Press again 		You will hear two 'pips' and the Voice Mute indicator will be lit. If you want <i>Continuous scanning</i> , go to step 4. To exit this mode go to step 5.
4.	Continuous scanning Press again 		You will hear a single 'pip' and the Voice Mute indicator will be off.
5.	To exit this mode, press 		



Using selective call in scan mode



Selective call scanning ensures that you are only alerted when the incoming calls are specifically addressed to you.

This facility also allows the Radiophone to store in memory the addresses of up to ten stations that may have tried to contact the Radiophone whilst unattended. These addresses may have been transmitted over any of the programmed channels.

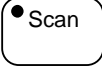

The first eight channels of the scan are used for selective call scanning.

For networks using this facility, it is important for the calling station to transmit a long preamble. For more details on selective calling, refer to section 5, *Using selective call*.

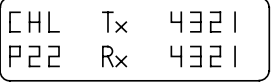
Ensure your Radiophone is switched on before commencing this procedure.

Step	Action...	Display shows...	Remarks...
1.	Press 	The display shows each channel as it is scanned.	The Scan indicator will be lit.
2.	Press 		On detection of a call, scanning stops until the call is decoded. If the call is addressed to your Radiophone you will hear a series of three telephone rings followed by pips every four seconds. If the call is not addressed to your Radiophone, the scan continues.



Step	Action...	Display shows...	Remarks...
3.	<p>If the call is addressed to the Radiophone the display changes.</p> <p>Every time an addressed call is detected, the display will repeat the same message with the appropriate channel frequency.</p>		<p>If the call is not answered immediately, the scanning stops for 2½ minutes and you will hear 'pips' every 4 seconds.</p> <p>After this period of time the Radiophone carries on scanning.</p>
4.	<p>To stop scanning press</p> 		<p>The button indicator will go out.</p>



Programming frequency band scan





The band scanning facility enables the Radiophone to scan between two programmed frequencies. You can program the frequency bands to suit your needs.

Up to 30 bands can be programmed into the Radiophone, and stored between channels P70 and P99.

There are two rates of scan available, fast and slow:

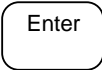
- fast scanning changes the frequency in ten 1 kHz steps per second
- slow scanning changes the frequency in ten 100 Hz steps per second.

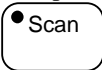

Your Radiophone must be switched on before commencing this procedure.

Step	Action...	Display shows...	Remarks...
1.	<p>The following buttons must be pressed within one second.</p> <p>Press</p>  <p>then press any of the Tune Rx Frequency buttons, example</p>  <p>then press</p> 		<p>The Scan button indicator flashes.</p> <p>The next action must start within 60 seconds.</p>



Step	Action...	Display shows...	Remarks...
2.	Using the numeric buttons, enter the start frequency to the nearest 100 Hz.		This is an example of selecting a band scan to start at 4000 kHz.
3.	Press		The decimal points are automatically entered by the Radiophone.
4.	Enter the stop frequency to the nearest 100 Hz.		This is an example of selecting a band scan to stop at 5000 kHz.
5.	Press		
6.	Press		S indicates the slow rate of scan (100 Hz steps).
	or		
			F indicates the fast rate of scan (1 kHz steps).

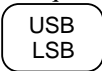

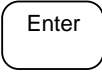
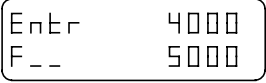
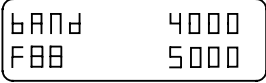
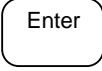
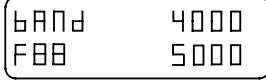
Step	Action...	Display shows...	Remarks...
7.	If a mode change is required, press 		Each press selects the next option; upper side band (U), lower side band (L), both side bands (LU) and back to (U).
8.	Press 		
9.	Enter the channel number you have selected. (eg 88)	 If the display shows either prog USEd, prog inhib or prog FULL refer to the notes on the next page.	You can select a number between 70 and 99. The F is automatically entered.
10.	Press 		The Scan indicator light goes out. The frequency band has been selected. You can repeat the operation until all the channels are full.



Notes: If the display shows 'prog USEd', either enter another channel number or press the Enter button to overwrite the existing information.

If the display shows 'prog inhib', the scan facility is inhibited. Refer to section 11, *Changing the set up options*.

If the display shows 'prog FULL', all 99 user program channels are used. Either press the Enter button to overwrite the existing information, or select a channel that you no longer require and press Enter.

Further details on these three messages can be found in *Programming display messages* in section 7.



Scanning frequency bands

The band scanning facility enables the Radiophone to scan between two programmed frequencies, refer to *Programming frequency band scan* on page 6-12.

There are two rates of scan available, fast and slow:

- fast scanning changes the frequency in ten 1 kHz steps per second
- slow scanning changes the frequency in ten 100 Hz steps per second.

The following steps explain how to scan the frequency bands:

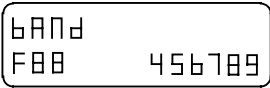

Step	Action...	Display shows...	Remarks...
1.	Ensure your Radiophone is switched on.		
2.	Select the relevant programmed band scan channel between P70 and P99.		Refer to section 4, <i>Selecting channels</i> . Band scan channels are indicated as an 'F' number.
3.	Press 	 The display shows the channel number and all the frequencies as the band is scanned continuously.	The Scan button indicator will be lit.

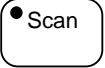
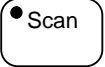
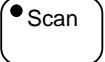

Step	Action...	Display shows...	Remarks...
4.	To pause the scan, press any of the fast or slow Tune Rx Frequency buttons. Example: 	The display shows the channel number and the current frequency.	You may move between the frequencies by using any of the Tune Rx Frequency buttons.
5.	To resume scanning, press 	The display shows the channel number and all the frequencies as the band is scanned continuously.	The rate of scan will be determined by whether you pressed the fast or slow button in step 3.
6.	To stop scanning, press 		The Scan button indicator will go out.
7.	To recommence normal scanning, select another non-band scanning channel and press 		Refer to section 4, <i>Selecting channels</i> .

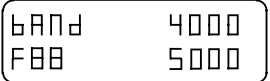
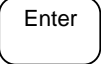
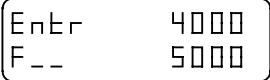

Deleting unwanted scan channels

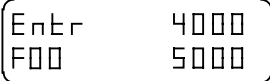
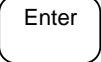
Step	Action...	Display shows...	Remarks...
1.	Ensure your Radiophone is switched on.		
2.	Select the channel you wish to delete.	 <p>An example for channel 88.</p>	Refer to section 4, <i>Selecting channels</i> .
3.	Press 		
4.	Press this button twice 		Two 0's entered as a channel number deletes the information in the selected channel.
5.	Press 	The display shows the details of the next lowest channel.	

Note: The scan program can be locked to prevent changes being made. If changes are attempted on a locked channel the display shows 'prog inhib'. If you need to amend this facility, refer to page 6-3 *Setting up the scan mode*.



7. Programming channels

Your Radiophone can store up to 600 channels. A maximum of 501 transmit and receive channels can be pre-programmed by the factory or a Codan agent. The remaining 99 programmable channels (P-channels) can be set by you from the front panel, either by copying from an existing programmed transmit/receive channel or adding a receive only frequency channel.

You cannot, however, change or program transmit frequencies from the front panel.

Existing options can be modified, such as:

- E-emergency call (RFDS)
- S-selective call
- t-calls (four 2-tone calls)
- Upper Side Band mode (USB) or Lower Side Band mode.

The factory or agent programmed channels are stored in the internal memory and can only be reprogrammed or deleted by the factory or agent.

P-channels are stored in memory but can be reprogrammed or deleted at any time by the operator.

All displays in this section show examples of channel and frequency numbers. You must insert your selected channel and frequency numbers.

8. Using tone call

The tone call facility allows stations within a network to call (tone encode-TE) other stations using the transmission of tones.

The following only applies where your Radiophone is required to operate into a private network using the transmission of tones for calling. The tone calling facility used for the RFDS and OTC (Telstra) services has already been programmed into the Radiophone for operation with the appropriate service channels—no further action is required by the user.

Tone calls use two tones (High and Low) transmitted simultaneously to call another station. The tones used must be identical for both the transmitting and receiving transceivers.

The tones fit into two frequency bands, each with a High and Low tone, either 440 Hz or 360 Hz apart. Each of these bands must lie within the frequency range 850 Hz and 1500 Hz.

The RFDS uses the 440 Hz frequency band, an example for this type of call would be 880 Hz and 1320 Hz. Private communications use the 360 Hz frequency band, a typical example for this type of call would be 880 Hz and 1240 Hz.

To transmit a tone call, tone call must be enabled on the selected channel.

The Radiophone cannot receive and decode tone calls

Selective call and tone call cannot be enabled on the same channel.









Tones t1 and t2 are given values in the factory. You can override these settings by using the following set-up procedure. To reinstate the original values, either enter '0' frequency or delete the latest channel information.

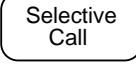
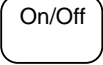

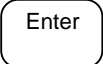

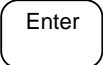
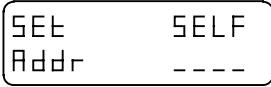
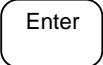
All displays in this section show examples of channel and frequency numbers. You must insert your selected channel and frequency numbers.

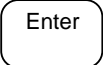
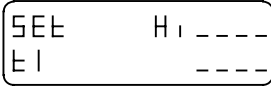
Setting up tone call

This procedure is similar to setting up selective call. Once in the set-up mode, you can skip through the non-important steps by pressing the Enter button.

Step	Action...	Display shows...	Remarks...
1.	To start the set-up mode, hold down  and press 		Hold the Call button down for approximately three seconds. This turns the Radiophone on, and into the preamble set-up mode.
2.	Press 		This set-up is not required.
3.	Press 		This set-up is not required.
4.	Press 		This set-up is not required.
5.	Press 		This part of the procedure allows you to enter the tone calling frequencies.

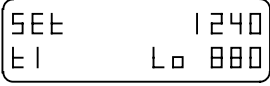

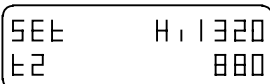
Step	Action...	Display shows...	Remarks...
6.	Use the numeric buttons to enter the t1 Hi tone frequency. Entering a new number overrides an existing frequency.	 <p>If you enter an incorrect frequency, the display shows an error. For further details, refer to section 12, <i>Display messages</i>.</p>	<p>There are four pairs of tone frequencies that you can set, t1, t2, t3 and t4.</p> <p>The t1 & t2 frequencies are pre-set in the factory. If you wish, you may alter settings.</p> <p>Each tone setting has a high and low frequency.</p>
7.	Press  You must complete the next step within 60 seconds.		<p>This sets the new t1 Hi tone frequency and allows you to set the t1 Low tone frequency.</p>
8.	Use the numeric buttons to enter the t1 Low tone frequency.		<p>Entering a new number overrides an existing frequency.</p>
9.	Press  You must complete the next step within 60 seconds.		<p>This sets the new t1 Low tone frequency and allows you to set the next tone pair t2.</p>



Step	Action...	Display shows...	Remarks...
10.	Steps 6 to 9 are repeated by the Radiophone for t2, t3 and t4.	<p>The display shows the same as in steps 6 to 9, except for the tone and frequency numbers.</p> <p>When all four tone pairs are recorded, the display returns to the first set-up option</p> <div style="border: 1px solid black; padding: 5px; text-align: center;">SEE CALL LONG</div>	
11.	Press <div style="border: 1px solid black; border-radius: 10px; padding: 2px 10px; display: inline-block;">On/Off</div>		This turns your Radiophone off and registers all the tone call settings you have just made.





Enabling a channel for tone calling

This procedure explains how to enable a channel for tone calling. Initially, you need to select a channel frequency you want to enable, and then choose a tone call pair for that frequency.

You can copy this information into the P-channel program.

This procedure is similar to *Enabling a channel for selective call* in section 5. Once in the set-up mode, you can skip through the non-important steps by pressing the Enter button.

The displays in this section will vary depending on the channel you select (ie the word inhibit may be replaced with a frequency number).

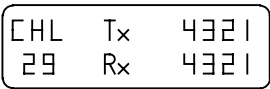
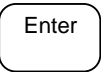
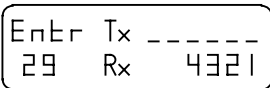
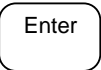
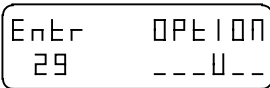
Step	Action...	Display shows...	Remarks...
1.	Use the Select Channel or Channel  and  buttons to find the channel you wish to enable.	 An example for channel 29.	Refer to section 4, <i>Selecting channels</i> .
2.	Press 		You will hear a 'pip'.
3.	Press 		You will hear a 'pip'.

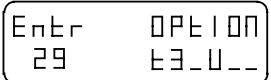
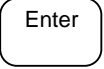
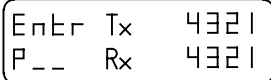
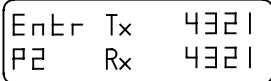
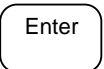
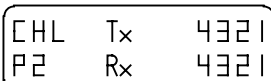
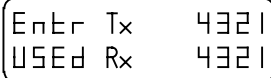

Step	Action...	Display shows...	Remarks...
4.	Press  Repeat this action until a 't' and the required tone pair appear in the left hand two spaces of the options bar.	 An example for tone pair t3.	You will hear a 'pip'.
5.	Press 		You will hear a 'pip'.
6.	Use the numeric buttons to enter the channel number you wish to use.		You will notice that the display automatically inserts a 'P' to the number.
7.	Press 	 If the channel is already used the display shows 	







Step	Action...	Display shows...	Remarks...
8.	If the channel is already used, you can either enter another number or press Enter again to override the existing one.	The display reverts back to normal.	The information will either be stored under an existing channel number, or you will have created a new one.

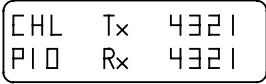
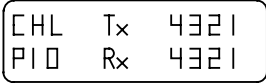

Transmitting a tone call

Before commencing this procedure, ensure the Voice Mute button is in the off position (indicator off) and the antenna is tuned to the selected frequency.

Step	Action...	Display shows...	Remarks...
1.	Use the Channel buttons or Select Channel button to select the channel you wish to use.		Ensure the channel you select is enabled for tone call. To check, press the Select Channel button.
2.	Ensure that the channel is free from traffic.		Listen for approximately 10 seconds.
3.	Press and hold  for approximately 10 seconds. If the channel you selected was not enabled, an error message will be displayed.	The display does not change. 	You will hear a tone and the Tx indicator will be lit. You will hear a low pitched tone. The call will not be transmitted, and you must choose another channel.
4.	You can start communication when contact has been established.		

Using tone call



9. Making a telephone interconnect call

If a base station transceiver is linked to an IPC-500 telephone interconnect unit (figure 9.1), it can make and receive telephone calls through the public switched telephone network (PSTN).

Using the selective call facility on your outstation Radiophone to signal the base station telephone interconnect, you can dial any telephone number of up to 16 digits. The number is sent as part of the selective call signal.

Your outstation Radiophone can store up to 10 pre-programmed telephone numbers which can be recalled for 'abbreviated dialling'. In addition, your outstation Radiophone can receive a selective call containing a telephone number which can be stored and reviewed later.

When the telephone mode is enabled, P-channels P90 to P99 are used for storage of telephone numbers with the base station telephone interconnect facility. These channels are no longer available for general use with channel frequencies.

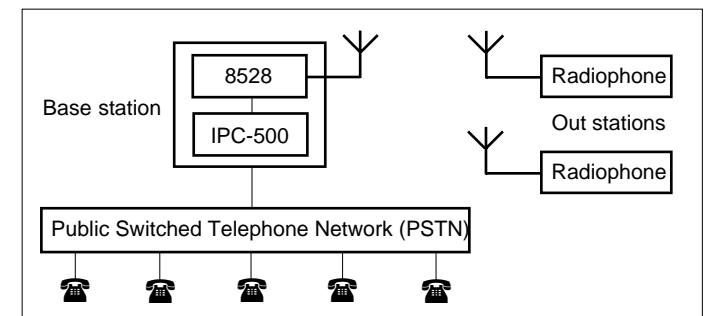



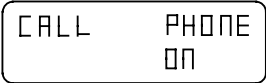
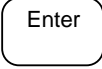

Figure 9.1: Telephone interconnect block diagram

Enabling the telephone mode

You can only make telephone calls from your outstation Radiophone if the telephone mode is enabled. You can still use all the Radiophone's other functions while this mode is enabled.

Step	Action...	Display shows...	Remarks...
1.	To enter the phone mode, hold down  and press 	Hold down the number 3 button until the display shows 	This turns the Radiophone on and into the phone set-up mode.
2.	Press  to switch between ON and OFF.		Continually pressing the number 3 button switches the telephone mode on and off.
3.	Switch the Radiophone off at your desired setting, or press 		This sets the telephone mode you require.



Making a telephone call





This procedure explains how to make a telephone call from your outstation Radiophone to the base station transceiver IPC-500 system.

Ensure your Radiophone is switched on before commencing this operation and the antenna is tuned on the selected channel, refer to *Tuning the antenna* in section 4.

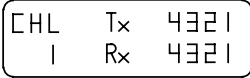

Notes: Before making a telephone call, it is often beneficial to make a beacon call to assess the best channel to use. Refer to *Using the beacon feature* in section 5.)

If you enter a wrong number, you can reset by pressing the Voice Mute button.

When you have finished making a call, you must disconnect the call line. (Refer to *Sending a disconnect message* on page 9-6.)

Step	Action...	Display shows...	Remarks...
1.	Use the Channel buttons or Select Channel button to select the channel you wish to use.	 <p>This is an example for channel 1.</p>	Refer to section 4, <i>Selecting channels</i> . Ensure the channel is enabled for selective call.
2.	Press 		You must start the next action within 60 seconds.
3.	Use the numeric buttons to enter the required selective call address.		This is the self identification number of the base IPC-500 telephone interconnect you are using. Refer to section 5, <i>Using selective call</i> .

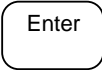

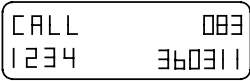
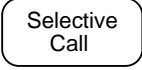
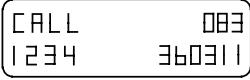
Step	Action...	Display shows...	Remarks...
4.	Press 		
5.	Use the numeric buttons to enter the telephone number you wish to call.		This example number is 08 336 0311. (Numbers wrap around in the display from the bottom to the top row, including the CALL area—16 digits.)
6.	Check the channel is free from traffic, then press 		<p>The Tx indicator lights and you will hear a warbling sound for approximately 10 seconds as the Radiophone sends your call.</p> <p>If the call is received successfully by the IPC-500 you will here a revertive tone, then there will be a pause while the number is being dialled. Once the number has been dialled by the IPC-500, you will hear the appropriate telephone network service tones.</p>

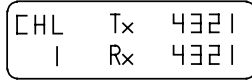

Step	Action...	Display shows...	Remarks...
7.	<p>When the telephone subscriber answers, they will hear a short pre-recorded message informing them that this is a radio telephone call.</p> <p>This is followed by a single tone of one second duration heard by both parties.</p> <p>You may now use the Radiophone in the normal communication mode.</p>		<p>The indicator light flickers whilst talking.</p> <p>On completing the call, you must send a disconnect message (refer to <i>Sending a disconnect message</i> on page 9-6).</p> <p>You may now resume normal Radiophone operation.</p>







Note: The telephone number is erased from memory once power has been turned off.



Sending a disconnect message

When a telephone call is made, a circuit is automatically established between your outstation Radiophone and the telephone party that the base IPC-500 has dialled. When you finish a call, this call line must be disconnected. This is achieved by sending a disconnect message from your Radiophone to the IPC-500.

This procedure assumes that the Radiophone is switched on and still on the original channel, and the telephone conversation has been completed.

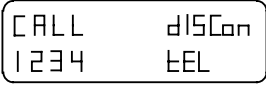
Step	Action...	Display shows...	Remarks...
1.	Press 		This is an example for the last called number 1234 on channel 1.
2.	Press 		The last telephone number you called was 08 336 0311.
3.	Press 		This deletes the last number.
4.	Press 		You are now ready to send the disconnect message.



Step	Action...	Display shows...	Remarks...
5.	Press 	The display does not change.	<p>The Tx indicator lights and you will hear a warbling sound for approximately 10 seconds as the Radiophone sends your call.</p> <p>When you hear five long beeps you know that the circuit has been disconnected.</p> <p>Your Radiophone is now ready for normal operation.</p>





Note: An alternative method of disconnect can be used by asking the telephone party to press '99' within two seconds on the DTMF telephone keypad.





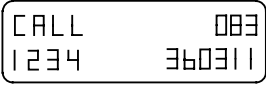

Storing a telephone number

This facility allows you to store up to 10 telephone numbers into your Radiophone, which can be re-called by entering a single code number (0 to 9) rather than a complete telephone number.

Ensure your Radiophone is switched on and a selective call enabled channel has been selected before commencing this procedure. If you make an error and wish to re-start this procedure (such as entering an incorrect number), just press the Select Channel button.

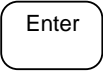
Step	Action...	Display shows...	Remarks...
1.	Press 		You must start the next action within 60 seconds.
2.	Use the numeric buttons to enter the required selective call address.		This is the self identification number of the base IPC-500 telephone interconnect you are using. See section 5, <i>Using selective call</i> .
3.	Press 		
4.	Use the numeric buttons to enter the telephone number you wish to store.		This example number is 08 336 0311. (Numbers wrap around in the display from the bottom to the top row, including the call area.)

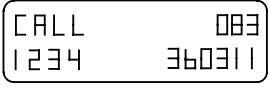
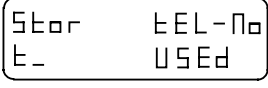







Step	Action...	Display shows...	Remarks...
5.	Press 		You can store this telephone number as a single code number, t0 to t9.
6.	Use the numeric buttons to enter the code number you want, 0 to 9.		Your selection has now been made.
	If the number you enter has already been used, the display will show USED and you will have to select another number or overwrite by pressing the number again.		
7.	Continually press the  button until the display shows the original channel settings.		Your Radiophone is ready for normal operation.



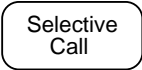

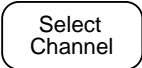
Reviewing the stored telephone numbers

This facility allows you to review all the numbers you have stored.

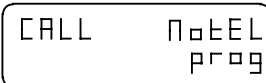
Ensure your Radiophone is switched on and a selective call enabled channel has been selected before commencing this operation.

Step	Action...	Display shows...	Remarks...
1.	Press 		You must start the next action within 60 seconds.
2.	Use the numeric buttons to enter the required selective call address.		This is the self identification number of the base IPC-500 telephone interconnect you are using. Refer to section 5, <i>Using selective call</i> .
3.	Press 		
4.	Press 		The display shows you the number first stored, in this example the number is 08 336 0311.
			If there are no numbers stored, the display will show

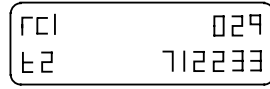

Step	Action...	Display shows...	Remarks...
5.	Keep pressing the  button to scroll through all the stored numbers.	 	This example is for number 02 971 2233. If you don't press Select Channel again, after one second the display changes to give you the option to call this number. Refer to page 9-12, <i>Calling a stored telephone number</i> .
6.	Continually press the  button until the display shows the original channel settings.		Your Radiophone is ready for normal operation.



Calling a stored telephone number

This procedure explains how to make a telephone call to a number you have previously stored.





Ensure your outstation Radiophone is switched on and a selective call enabled channel has been selected before commencing this operation.

Ensure the antenna is tuned on the selected channel, refer to *Tuning the antenna* in section 4.

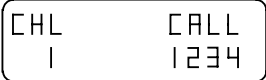

Notes: Before making a telephone call, it is often beneficial to make a beacon call to assess the best channel to use. (Refer to *Using the beacon feature* in section 5.)

If you enter a wrong number, you can reset by pressing the Display button.

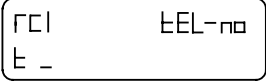
When you have finished making a call, you must disconnect the call line. (Refer to *Sending a disconnect message* on page 9-6.)

Step	Action...	Display shows...	Remarks...
1.	Press 		You must start the next action within 60 seconds.
2.	Use the numeric buttons to enter the required selective call address.		This is the self identification number of the base IPC-500 telephone interconnect you are using. Refer to section 5, <i>Using selective call</i> .
3.	Press 		

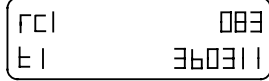
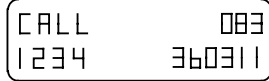

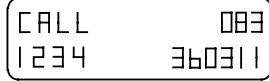
Step	Action...	Display shows...	Remarks...
4.	Use the numeric buttons to enter the number you require between 0 and 9.	 <p>After one second the display changes to</p> 	This example shows the recall number t1, and the telephone number to call as 08 336 0311.
5.	<p>Check that the channel is free from traffic, then press</p> 		<p>The Tx indicator lights and you will hear a warbling sound for approximately 10 seconds as the Radiophone sends your call.</p> <p>If the call is received successfully by the IPC-500, you will here a revertive tone then there will be a pause while the number is being dialled. Once the number has been dialled by the IPC-500, you will hear the appropriate telephone network service tones.</p>

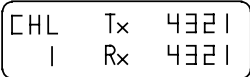

Step	Action...	Display shows...	Remarks...
6.	<p>When the telephone subscriber answers, they will hear a short pre-recorded message informing them that this is a radio telephone call.</p> <p>This is followed by a single tone of one second duration heard by both parties.</p> <p>You may now use the Radiophone in the normal communication mode.</p>		<p>The indicator light flickers whilst talking.</p> <p>On completing the call, you must send a disconnect message (refer to <i>Sending a disconnect message</i> on page 9-6).</p> <p>You may now resume normal Radiophone operation.</p>





Deleting a stored telephone number





This facility allows you to delete a stored telephone number. Ensure your Radiophone is switched on and a selective call enabled channel has been selected before commencing this operation.

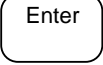
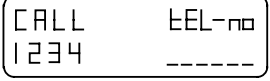

As soon as you enter the number to be deleted, it is deleted immediately from memory without any warning. To prevent deleting numbers you need, ensure you make the correct choice first time, you do not get a second chance.

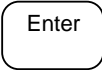
Step	Action...	Display shows...	Remarks...
1.	Press 		You must start the next action within 60 seconds.
2.	Use the numeric buttons to enter the required selective call address.		This is the self identification number of the base IPC-500 telephone interconnect you are using. Refer to section 5, <i>Using selective call</i> .
3.	Press 		If a telephone number appears in this display, press the Voice Mute button to clear this number. (This will have been the last number called.)

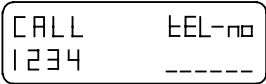

Step	Action...	Display shows...	Remarks...
4.	Press 		
5.	 See page 9-15. Use the numeric buttons to enter the stored number you want to delete, 0 to 9.		
6.	Continually press  until the display shows the original channel settings.		Your Radiophone is ready for normal operation.



Received call messages

When a call has been received and decoded, the display provides you with different messages to indicate the type of call received. The following examples show you the type of messages that will appear on the display.

This display...

```

CHL          428
P2          CALLED
  
```

Means...

An ordinary (not telephone) selective call has been received from station 428 on channel P2.

```

CHL          428
P2          T-CALL
  
```

A telephone call from station 428 containing telephone number information has been received on channel P2.

```

CALd Tx    4012
400 Rx    4012
  
```

A call has been received on another channel. This example shows a call whilst the Radiophone is on channel 400 and the channel frequencies.

```

CHL          CALLED
P2          Rx 1.234.0
  
```

An ARQ call has been received on channel P2.



Reviewing the list of received calls in memory

Your Radiophone is able to record up to 10 calls in memory from various stations. These may be on different channels if your Radiophone is in scan mode. These calls are recorded in a memory stack awaiting your review. If a station calls more than once on the same channel, your Radiophone only records one of the calls. If more than 10 calls are made to your Radiophone, the first call stored in memory is deleted to make room for the latest call.

Ensure your Radiophone is not in the scan mode before commencing this procedure.







A permanent or brief loss of power to your Radiophone will delete information stored in memory . Ensure you record or use all the information stored in the memory stack before switching off the Radiophone.

Notes: If the Radiophone power is lost momentarily (such as during starting the vehicle engine), the call memory is retained but the telephone number is lost.

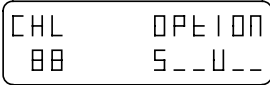
Switching the Radiophone off using the On/Off button deletes all calls stored in the memory stack.

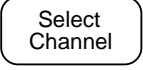
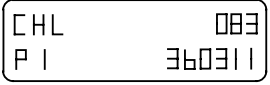
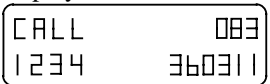
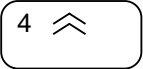
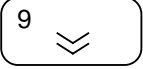

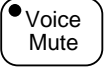
Step	Action...	Display shows...	Remarks...
1.	Press and hold 		The options for the channel are displayed.
2.	Release  and within one second press 	If any calls have been recorded, the display shows  and after one second the display shows  If no calls have been received, the normal channel display will remain.	The first call recorded will be displayed first. In this example, a call was received on channel P1 from telephone number 08 336 0311. The display now shows you the self identification address, 1234, of the station that called.
3.	Press either  or 	The display shows the next call, and after one second the self identification address of the caller.	Pressing either the channel  or  button scrolls you through the list of received calls recorded in the memory.
4.	Press  to return to normal operation.		To reply to any of these calls, refer to <i>Returning a call</i> on page 9-20.



Returning a call

This procedure explains how to return a telephone call to one of the numbers recorded in the memory stack.

Ensure your Radiophone is switched on before commencing this operation.

Ensure the antenna is tuned on the selected channel, refer to *Tuning the antenna* in section 4.



A permanent or brief loss of power to your Radiophone will delete information stored in the memory stack. Ensure you record or use all the information stored in the memory stack before switching off the Radiophone.

Notes: If the Radiophone power is lost momentarily (such as during starting the vehicle engine), the call memory is retained but the telephone number is lost.



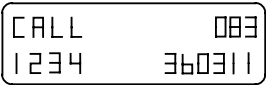

Switching the Radiophone off using the On/Off button deletes all calls stored in the memory bank.

Before making a telephone call, it is often beneficial to make a beacon call to assess the best channel to use. (Refer to *Using the beacon feature* in section 5.)

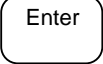
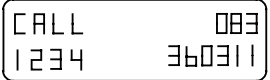

When you have finished returning calls, you must disconnect the telephone line. (Refer to *Sending a disconnect message* on page 9-6).

Step	Action...	Display shows...	Remarks...
1.	Select the call you wish to make (see <i>Reviewing the list of received calls in memory</i> on page 9-18, steps 1 & 2).		This display example shows the phone number 08 336 0311 and the self identification address 1234 of the caller.



Step	Action...	Display shows...	Remarks...
2.	Press 		The transceiver automatically selects the correct channel, and displays the self identification address (1234) of the caller.
3.	Press 		
4.	Check that the channel is free from traffic, then press 	The display does not change.	The Tx indicator lights and you will hear a warbling sound for approximately 10 seconds as the Radiophone sends your call. If the call is received successfully by the IPC-500 you will here a revertive tone, then there will be a pause while the number is being dialled. Once the number has been dialled by the IPC-500, you will hear the appropriate telephone network service tones.

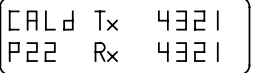

Step	Action...	Display shows...	Remarks...
5.	<p>When the telephone subscriber answers, they will hear a short pre-recorded message informing them that this is a radio telephone call.</p> <p>This is followed by a single tone of one second duration heard by both parties.</p> <p>You may now use the Radiophone in the normal communication mode.</p>	<p>The display shows</p>  <p>for any call that has not been returned.</p>	<p>The indicator light flickers whilst talking.</p> <p>The viewed call is deleted from the memory stack when you press the PTT button on the microphone.</p> <p>On completing the call, you must send a disconnect message (refer to <i>Sending a disconnect message</i> on page 9-6).</p>
6.	<p>Repeat steps 1 to 5 to clear all calls stored in the memory stack.</p>		
7.	<p>Press</p>  <p>to return the Radiophone to normal operation.</p>		



10. RFDS and Telstra services

The Radiophone has been customised for simple operation into the following remote area safety services:

- the Royal Flying Doctor Service (RFDS)
- Telstra (formerly OTC).

Channel frequencies for both services have been programmed into the Radiophone and some front panel controls have been dedicated to operate into those facilities provided.

This section briefly covers the services offered by each organisation and details the procedures required to use these services.

Royal Flying Doctor Service

The Royal Flying Doctor Service (RFDS) is a vital communications link in the Australian outback. Apart from maintaining contact and a listening watch for medical services, the organisation also provides general communication facilities which includes radiotelephone and lettergram services.

Each base station is allotted with a unique range of channel frequencies, some of which may be used to provide a day and night communications watch for medical aid and assistance.

It is most important before embarking on a trip, or entering into an area covered by a base station, that the listening watch frequencies and operating times are known—your transmission may never be heard if you have chosen the wrong channel to make a call for help.

How to contact the RFDS

To contact an RFDS base station, select the station primary frequency and tune the antenna. Before transmitting, check that the channel is not being used and follow the procedure in section 4, *Transmitting*.

Emergency communications

Each RFDS base station has its own specified times for routine medical consultation. If during normal RFDS base station hours medical advice is required and cannot wait until the routine medical session, the following procedure should be adopted:

- wait until the first quiet moment on the frequency
- transmit and call the base station by call sign, give your own call sign and then mention that this is an urgent medical call.



On receipt of this call, the RFDS base station will deal only with the outstation seeking medical advice. Should the frequency in question be heavily congested with traffic and 'quiet' periods are not forthcoming, the above medical call should be proceeded by a 20 second RFDS emergency alarm call.

If medical assistance is required at a time when the RFDS base station is normally closed, at night or at weekends, then you should complete the procedure on page 10-4, *Making an RFDS emergency call*.

If the RFDS base station has heard your call it will respond within two minutes with a transmitted tone – you can be assured that either the local hospital or police station have been notified that you are in need of assistance. RFDS staff will respond within five minutes of the call being transmitted and will ask for the station making the emergency call to 'identify themselves'. You must then respond in the manner outlined in the procedure *Making an RFDS emergency call* on page 10-4.



RFDS and St Johns Ambulance Stations

Control Station	Call Sign	Telephone
Alice Springs	VJD	(089) 52 1033
Broken Hill	VJC	(080) 88 0777
Cairns	VJN	(070) 53 1952 (070) 53 1954
Carnarvon	VJT	(099) 41 1758
Charleville	VJJ	(076) 54 1233
Derby	VJB	(091) 91 1211
Kalgoorlie	VJQ	(090) 21 2211
Meekatharra	VKJ	(099) 81 1107
Mount Isa	VJI	(077) 43 2800
Port Augusta	VNZ	(086) 42 2044
Port Hedland	VKL	(091) 73 1386
St Johns (Darwin)	VJY	(089) 45 2455

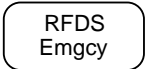
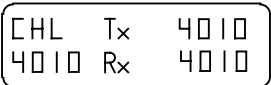

Making an RFDS emergency call

The RFDS Emgcy button is used to call the Royal Flying Doctor Service. This button will only function if the selected channel is enabled for emergency calls.

Step	Action...	Display shows...	Remarks...
1.	Select the correct RFDS channel for the base station required. You can use the channel or recall buttons, then tune the antenna.		Refer to section 4, <i>Tuning the antenna.</i>
2.	Press 		When you press the RFDS Emgcy button you will hear a tone. After the 'pip', the tone continues for 20 seconds. During this period the Tx indicator will be lit.
3.	If you hear a single low pitched tone and the display shows 'Not ENABLE', the channel is not an RFDS frequency and cannot be used for an emergency call.		Try again and select a correct RFDS channel.



Step	Action...	Display shows...	Remarks...
4.	Wait for a reply before transmitting your message.	The display does not change.	<p>If the call was received by an attended RFDS base, they will reply immediately.</p> <p>If the call was received by an unattended RFDS base, a tone will be transmitted automatically within two minutes.</p> <p>If the tone call is not received, you should try again or go to another channel.</p>
5.	<p>To cancel a call during the 20 second transmission time either press</p> <div data-bbox="1339 882 1440 954" style="border: 1px solid black; border-radius: 15px; padding: 5px; width: fit-content; margin: 0 auto;">Tune</div> <p>the PTT switch on the microphone or the</p> <div data-bbox="1339 1066 1440 1137" style="border: 1px solid black; border-radius: 15px; padding: 5px; width: fit-content; margin: 0 auto;">On/Off</div> <p>button.</p>		



Telstra Radphone Service

Telstra Mobile Satellite and Radio Services (formerly OTC maritime) provide the Radiophone user with the ability to access the public switched telephone network (PSTN) at any time of the day or night. This brings the convenience of home or office to the outback traveller through the radio telephone facility of your Radiophone and the Telstra organisation. Calls can be transmitted or received just like a normal telephone.

The services provided by Telstra include:

- Radphone Direct Dial for direct dialling from your Radiophone without operator assistance
- Radphone Selcall operator connected telephone calls for registered selcall users
- Radphone operator connected for non-registered selcall users.

To register for 'Radphone Direct Dial' or 'Radphone Selcall' and for details of other Telstra services, you are recommended to contact the Telstra Customer Service Centre on Freecall 1800 810 023 or (02) 901 2103.

Calling a Telstra station can be accomplished using the selective call facility (which is recommended), tone calling or by voice on the appropriate Telstra channel where indicated in the frequency list handbook supplied with your Radiophone.

It is most important that the correct frequency is selected for initial contact with a Telstra station as a listening watch is only kept on the 'voice calling' channels.

For operation into the Telstra Radphone service your Radiophone front panel markings and display will show **OTC**—the original name. For further reading and information you are recommended to obtain a copy of the Telstra 'Radphone Users Guide'.



Transmitting a Telstra (OTC) selective call—Selcall

This procedure explains how to contact a Telstra station selectively to initiate a telephone call through the Telstra Radphone operator using the ‘Radphone Selcall’ and ‘Radphone’ services.

Registered users of the ‘Radphone Direct Dial’ service will receive a separate user guide detailing the operating requirements of that service.





It is assumed your Radiophone has been programmed with your self-identification number issued by Telstra Customer Service Centre.

Ensure your Radiophone is switched on before commencing this operation and the antenna is tuned on the selected monitored (selcall) channel, refer to *Tuning the antenna* in section 4.

Before making a telephone call, it is often beneficial to make a beacon call to assess the best channel to use. Refer to *Transmitting a Telstra selective beacon call* on page 10-10.

Step	Action...	Display shows...	Remarks...
1.	Ensure the S'Call Mute is off, if necessary press		The S'Call Mute indicator will be off when the mute is off.



Step	Action...	Display shows...	Remarks...
2.	<p>Press</p>  <p>and then press</p>  <p>until the required selective call address appears against the Telstra station selected.</p>		<p>A table of all the Telstra station selcall address numbers is shown on page 10-9.</p>
3.	<p>Press</p> 	<p>The display returns to normal.</p>	<p>The selective call signal is transmitted.</p> <p>If the call is successful, the Telstra station will automatically respond with a series of short tones. The station operator will then respond with normal voice communication.</p>
4.	<p>Use the microphone to carry out normal voice communication.</p>		<p>Refer to section 4, <i>Using the microphone</i>.</p>







Note: if the call is not successful, either the channel chosen is not a monitored, or selcall, channel for the Telstra station called, or the frequency is not appropriate for the time of day and range you are working. Check the channel frequencies listing for the station being called, if necessary choose another channel.

The Telstra station selcall address numbers		
Brisbane	BRIS	0104
Darwin	DAR	0105
Melbourne	MELB	0106
Perth	PERTH	0107
Sydney	SYDNEY	0108
Townsville	TNSL	0109

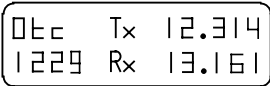
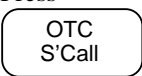

Transmitting a Telstra selective beacon call

The beacon facility is used to check signal conditions between your Radiophone and a selected Telstra station.

Step	Action...	Display shows...	Remarks...
1.	Ensure your Radiophone is switched on.	The last channel selected.	
2.	Select the required test channel and tune the antenna.		Refer to section 4, <i>Selecting channels</i> .
3.	Press 		When this button is pressed, the S'Call Mute is automatically switched off.
4.	Press  until the required selective beacon address number appears against the Telstra station selected .		This example allows you to send a Telstra selective beacon call to Brisbane-104.

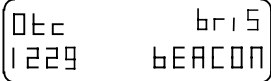

Step	Action...	Display shows...	Remarks...
5.	<p>Check that the channel is free from traffic, then press</p>  <p>(beacon call button)</p>	 <p>Immediately the call is received, the display shows the last channel and transmit & receive frequencies used.</p>	<p>The transmit indicator will be lit and you will hear a warbling sound for approximately 10 seconds. If the call is successfully decoded you will hear four long revertive tones.</p> <p>You can check these tones for signal strength and compare them with signal strengths from other channels. Select the channel giving the best return signal strength.</p>



Receiving a Telstra selective call

This procedure explains how a telephone call is received on your Radiophone through Telstra from the public telephone service.

It should be noted that telephone subscribers can book a radio-telephone call to you by dialling the national Telstra booking number 0108.

Calls will only be decoded if your Radiophone is switched on and in either the:

- selective call scan mode (refer to section 6, *Using selective call in scan mode*) which is recommended when expecting a call
- set on the correct channel for the time of day and the antenna is tuned on the selected channel, refer to *Tuning the antenna* in section 4.

Step	Action...	Display shows...	Remarks...
1.	No action, the Radiophone automatically completes this event.	 <p>The display shows that you have received a Telstra (OTC) call and the address of the calling station.</p>	This is an example of a Telstra call from the Brisbane station with selcall ident number 0104.

Notes: On receipt of a call you have two options:

- either answer it immediately, refer to *Answering a received call* in section 5
- let the Radiophone automatically store the callers self identification number in memory to await your reply, refer to *Returning a received call-general* in section 5.

If your Radiophone was unattended at the time the selective call was received, the callers self identification number is stored in memory for you to review at a later time. Refer to *Reviewing the list of received calls in memory* in section 5.



- Notes cont.
- If you do not answer the call immediately, once the call is stored in memory your Radiophone will continue to give out 'pips' every four seconds to indicate that a call has been received. If you wish to silence these 'pips', yet still retain the display, press the Selective Channel button.
- If you only wish to receive selective calls, ensure the S'Call Mute button is operated and the indicator lit.
- If the microphone PTT button is not pressed before the end of the tones:
- the called display will remain on to indicate that a call was received
 - a 'pip' will be heard every four seconds
 - the external alarm relay contacts will close for approximately two minutes (refer to section 5, *Using the external alarm feature*).





Transmitting a Telstra (OTC) tone call

The tone call facility allows you to call a Telstra station using the transmission of a simple signalling system—OTC tone call. It should be noted that whilst the tone call facility is available it is recommended that, where ever possible, all calls to Telstra are initiated by the selective call procedure—the preferred method of establishing contact.

Before commencing this procedure, ensure the Voice Mute button is in the off position (indicator off) and the antenna is tuned to the selected frequency.

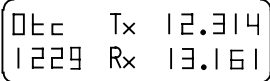
The 'OTC Tone Call' button only operates on OTC designated channels.

Step	Action...	Display shows...	Remarks...
1.	Use the channel buttons or Select Channel button to select the OTC (Telstra) channel you wish to use.		
2.	Ensure that the channel is free from traffic.	The display does not change.	Listen for approximately 10 seconds.
3.	Press and hold  for approximately 10 seconds.	The display does not change.	You will hear a tone and the Tx indicator will be lit.
4.	You can start communication when contact has been established. If there is no response to your call after two minutes, repeat steps 1–3 or select another channel or Telstra station.		



11. Changing the set-up options

Some of the set-up options in this section can be completed by the user, others must only be carried out by qualified personnel, either at the Codan factory or by a Codan agent. A statement is made in the procedure whenever qualified personnel are required.

All displays in this section show examples of channel and frequency numbers. You must insert your selected channel and frequency numbers.

Set-up option links

Some of the set-up procedures may need a link to be moved inside the control head, while some need a link soldered inside the transceiver. The moveable link is called the control head link (refer to figure 11.1), the soldered link is called the microprocessor link (refer to figure 11.2).



The control head link

The control head link is located on the control head printed circuit board (PCB) assembly (part number 08-04666-001).

The PCB is located inside the control head. The link is located on a row of four vertically mounted pins on the PCB (figure 11.1), immediately behind the number 7 button.

There are two links fitted to the PCB, the fixed link which must always remain across pins 2. If this link is removed, the Radiophone will not operate correctly.

The control head link is fitted across pins E and must be moved to pins 1 when completing the set-up options:

2 remains permanently in this position

1 used for set-up options

F not used

E control head link.

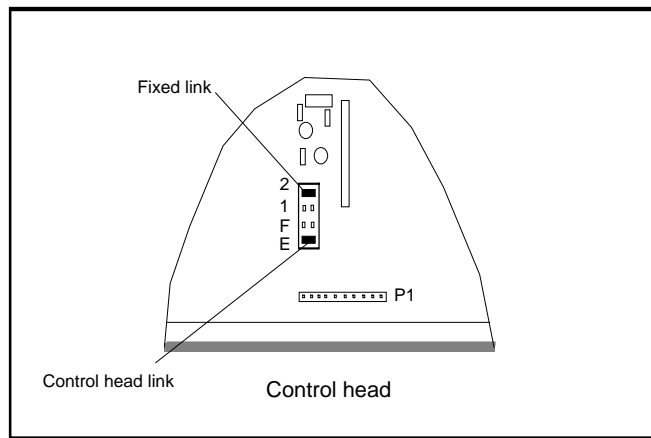

Figure 11.1: The control head link

Changing the position of the control head link

The control head link is a black plastic moulding incorporating linked metal contacts. The contacts short together pins located on the control head PCB.



Extreme care should be taken when handling the control head to prevent damage to the components.

Step	Action
1.	Turn the Radiophone off and disconnect the power.
2.	Remove the control head rear panel.
3.	Move the control head link from position E to position 1.
4.	You can now carry out the relevant set-up procedures.
5.	After completing the set-up procedures, turn the Radiophone off and disconnect the power before returning the link to its original position.
6.	Replace the cover before reconnecting the power to your Radiophone. Your Radiophone is now ready for normal use.



The microprocessor PCB link

The microprocessor link is one that you will have to make and solder on the microprocessor PCB. The PCB (part number 08-03741-001) is positioned on the underside of the transceiver.

The link must only be soldered across the number 2 pads as shown in figure 11.2. A link soldered across pads 2 (called the inhibit link) prevents you from changing the inhibit set-up options on P-channel programming.

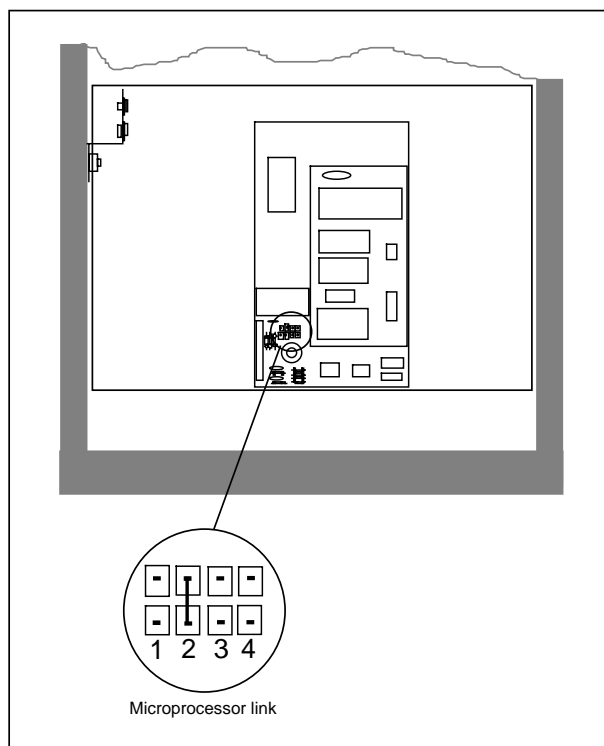

Figure 11.2: The microprocessor link

Inserting the microprocessor PCB link



Extreme care should be taken when handling the transceiver to prevent damage to the components.



This procedure must only be carried out by a qualified technician.

Step	Action
1.	Turn the Radiophone off and disconnect the power.
2.	Lay the transceiver on its top with the front panel facing you.
3.	Remove the bottom cover of the transceiver.
4.	Locate the microprocessor PCB and the number 2 pads (refer to figure 11.2). The link must only be fitted across pads 2. Pads 1, 3 & 4 are not used.
5.	Solder a suitable piece of wire across pads 2 (the Inhibit link).
6.	Carry out the relevant set-up procedures.
7.	After completing the set-up procedure, turn the Radiophone off and disconnect the power. This link must be left in the new position.
8.	Replace the cover before reconnecting the power to the Radiophone. The Radiophone is now ready for normal use.

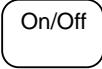

Reviewing set-up options

This facility allows you to see what set-up options have been enabled with the Radiophone. You can review the set-up options at any time.

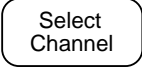
Step	Action...	Display shows...	Remarks...
1.	Ensure your Radiophone is off.	No display.	
2.	Hold down  and press 	Hold down the Select Channel button until the display shows 	The display starts with the scan set-up option.
3.	To scroll through the options press 	Shows each option.	Each press of the Select Channel button scrolls the following options: SCAN prog ENAbLE CHAN No inhib diSP S-CALL ENAbLE diSP CALL LONG diSP Addr CALL diSP Addr SELF diSP bEACON ON diSP t1 Hi Lo diSP t2 Hi Lo diSP t3 Hi Lo diSP t4 Hi Lo Ptt CutOut diSP bEEPS loud CALL PHONE OFF Ant Contrl CHAN or bANd.





Step	Action...	Display shows...	Remarks...
4.	To exit the review mode and resume normal operations, press the PTT button.		



PTT timer

This facility stops the Radiophone from being left on in the transmit state. If the transmit time exceeds the PTT timer setting, the Radiophone reverts to the receive mode and an error message is displayed.

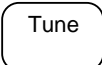
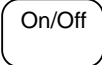
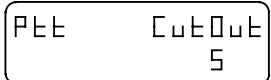
The timer is set at the factory to 10 minutes. You may turn this facility off, or vary the time, in five minute intervals, between 5 and 35 minutes.

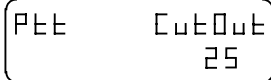
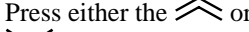
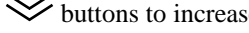
Step	Action...	Display shows...	Remarks...
1.	Turn the Radiophone off and move the control head link from position E to position 1.	No display.	Refer to the procedure on page 11-3.
2.	Hold down  and press 	Hold the Tune button down until the display shows 	This turns the Radiophone on, and into the PTT timer set-up mode.
3.	Press  or 		The PTT time out time can be changed from 5 to 35 minutes. Press either the  or  buttons to increase or decrease the time. Stop at the setting you require.

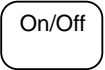

Step	Action...	Display shows...	Remarks...
4.	Press 	No display.	Your selection has been made and the Radiophone is now switched off.
5.	Return the control head link to its original position (E).		Refer to the procedure on page 11-3.
6.	Replace the cover before switching on your Radiophone.		Refer to the procedure on page 11-3.



Enter a PIN (Personal Identification Number)



If you select a PIN for the Radiophone, you will have to enter this PIN each time you switch the Radiophone on. If you fail to enter the correct PIN, the Radiophone will automatically switch off.



If a PIN code is set, the Radiophone can only be operated by entering the PIN.

**It is important that every person who uses the Radiophone knows the PIN.
Alternatively, do not set the PIN code.**

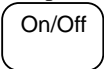
Should you forget the PIN, you will have to return the transceiver to the factory.



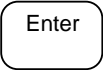
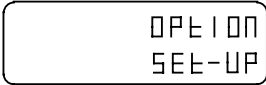
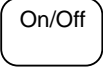

Step	Action...	Display shows...	Remarks...
1.	Turn the Radiophone off and move the control head link from position E to position 1.	No display.	Refer to the procedure on page 11-3.
2.	Hold down  and press 	Hold down the Tune Rx Fast button until the display shows 	This switches your Radiophone on and into the PIN set-up mode.
3.	Use the numeric buttons to enter your PIN.	The display will show the number you enter.	You can select a number between 1 and 999999. 

Step	Action...	Display shows...	Remarks...
4.	Press 		Your PIN number has now been registered within the Radiophone.
5.	Press 	No display.	The Radiophone is now switched off.
6.	Return the control head link to its original position (E).		Refer to the procedure on page 11-3.
7.	Replace the cover before switching on your Radiophone.		Refer to the procedure on page 11-3.

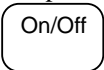

Changing or deleting a PIN

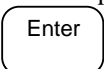
This procedure allows you to change your PIN, or delete it.

Step	Action...	Display shows...	Remarks...
1.	Turn the Radiophone off and move the control head link from position E to position 1.	No display.	Refer to the procedure on page 11-3.
2.	Hold down  and press 	Hold down the Tune Rx Fast button until the display shows 	This switches your Radiophone on and into the PIN set-up mode.
3.	Use the numeric buttons to enter your existing PIN		Example of existing PIN number 1234.
	and then press 		You may now change or delete the PIN.

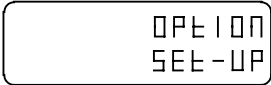

- | | | |
|---|---|--|
| <p>4. To insert a new PIN, use the numeric buttons and press</p> | <p>The display will show the number you enter, or if you cleared the PIN</p> | <p>You can select a number between 1 and 999999.</p> |
| <p style="text-align: center;">Enter</p> |  | <p>A new PIN is now registered, or the old PIN has been cleared.</p> |
| <p>To clear a PIN, do not insert new numbers, just press</p> | <p style="text-align: center;">Enter</p> | |
| <p>5. Press</p> | <p style="text-align: center;">On/Off</p> | <p>No display.</p> |
| <p>6. Return the control head link to its original position (E).</p> | | <p>Refer to the procedure on page 11-3.</p> |
| <p>7. Replace all covers before switching on your Radiophone.</p> | | <p>Refer to the procedure on page 11-3.</p> |



Power-on settings



There are two power-on settings that may be set at any time without the need to move or install any internal links. These are the default settings that will always be present when you switch on the Radiophone.

- **Mute settings.** This facility allows you to select either Voice Mute on/off, or S'Call Mute on/off.
- **Beep volume.** This facility allows you to set the beep volume to either loud or soft.

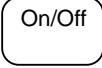
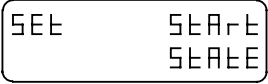
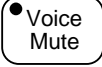
Mute settings





Step	Action...	Display shows...	Remarks...
1.	Hold down  and press 	Hold down the Voice Mute button until the display shows 	This switches your Radiophone on and into the Mute set-up mode.
2.	To select either Voice Mute on or off, press 	No change in the display.	The Mute is on when the indicator is lit. If you wish to select Voice Mute on, proceed to step 4. If you wish to select S'Call Mute proceed to step 3.



Step	Action...	Display shows...	Remarks...
3.	To select S'Call Mute on, press  to select S'Call Mute off press 	No change in the display.	The S'Call Mute is on when the indicator is lit.
4.	Press 	Reverts to normal display showing channel and frequency numbers.	Your selection has been made and you can switch off the Radiophone.

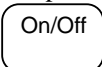
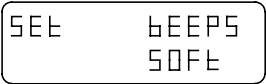
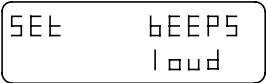

Beep volume

Step	Action...	Display shows...	Remarks...
1.	Hold down  or  and press 	Hold down either of the volume buttons until the display shows  or 	This switches your Radiophone on and into the beep volume set-up mode. The display will show the last beep volume setting.
2.	Press either of the volume buttons to switch between the beep volume settings.	The display will switch between SOFT and loud.	
3.	Press 	Reverts to normal display showing channel and frequency numbers.	Your selection has been made and you can switch off the Radiophone.





Clear all settings and P-channels

This facility allows you to clear all settings (except the PIN number) and P-channels automatically. Ensure your Radiophone is switched off before commencing this procedure.

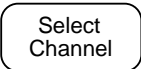
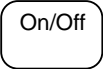
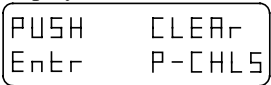
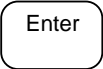

Do NOT use this facility if you require any of the P-channels. To restore the transmit frequencies may be extremely difficult.

Step	Action...	Display shows...	Remarks...
1.	Hold down  and press 	Hold down the Select Channel button until the display shows 	This switches your Radiophone on and into the Clear all settings and P-channels set-up mode.
2.	Press  and wait until the display shows dONE.		All settings and P-channels have now been cleared. You can now switch off the Radiophone.



12. Display messages







In addition to showing the normal channel information, the display is able to show messages indicating the results of an operation, such as an operator error or a system error.

These error or fault messages are generally accompanied by one or more 'beeps'.



If a Radiophone fault is indicated, the Radiophone must be switched off and tried again. If the fault re-occurs the Radiophone must be sent to Codan, or a Codan agent, to have the fault rectified.

Messages will be displayed for five seconds and then normal operation will be resumed. Pushing any button or the microphone PTT button during this five second period will immediately restore normal operation.

Messages and operator errors

No. of 'beeps'	Message displayed	Meaning
2		The automatic antenna has been satisfactorily tuned.
2		The automatic antenna has failed to tune.
2		An attempt has been made to transmit before the automatic antenna has been tuned. Wait until the automatic antenna has tuned. If a fault exists, refer to the antenna handbook for details.
1		An attempt has been made to enter more than 15 channels in the scan program.
0		Displayed when programming scan and shows that a channel has been entered in the scan program.
1		Channel does not exist.

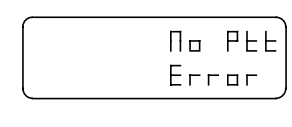

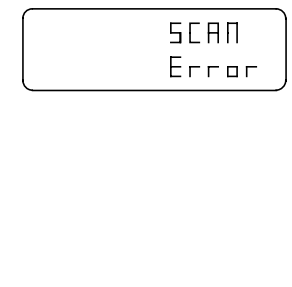
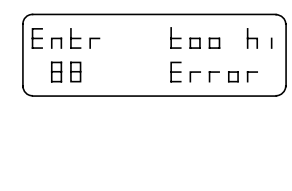
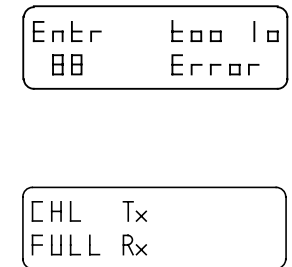
No. of 'beeps'	Message displayed	Meaning
1		<p>An attempt has been made to transmit on a receive-only channel, or while the scan mode is selected.</p> <p>If the Radiophone is scanning, press the Scan button to stop scanning. If the channel selected is a receive-only channel, select another channel.</p>
1		<p>An attempt has been made to select the scan mode while the Radiophone is transmitting, or no channels have been entered in the scan program.</p> <p>Check that the program has scan channels, if not select another program.</p>
1		<p>An attempt has been made to program a receive frequency higher than 30,000 kHz or a tone frequency higher than 2800 Hz.</p>
1		<p>An attempt has been made to program a channel with a frequency lower than 250 kHz or a tone frequency of 300 Hz or lower.</p>
0		<p>All 99 P-channels are programmed.</p>



Display messages

No. of 'beeps'	Message displayed	Meaning
1	<div style="border: 1px solid black; padding: 5px; display: inline-block;"> CHL Tx USEd Rx </div>	The nominated channel is already programmed.
1	<div style="border: 1px solid black; padding: 5px; display: inline-block;"> prog inhibit </div>	There are four program inhibit options available. Refer to <i>Setting up the P-channel inhibit options</i> in section 7.
1	<div style="border: 1px solid black; padding: 5px; display: inline-block;"> PoE ENABLE </div>	An emergency call, tone call or a selective call has been attempted on a channel where that function has not been enabled.
1	<div style="border: 1px solid black; padding: 5px; display: inline-block;"> Po Rx TUNE </div>	Full inhibit has been programmed.
2	<div style="border: 1px solid black; padding: 5px; display: inline-block;"> PTT Cutout </div>	The microphone PTT has been active for a longer time period than set. Refer to section 11, <i>Changing the set-up options..</i>
1	<div style="border: 1px solid black; padding: 5px; display: inline-block;"> CHL CALL ---- </div>	A request for you to enter a selective call address.
1	<div style="border: 1px solid black; padding: 5px; display: inline-block;"> CALL PHONE OFF </div>	The telephone mode is off.



No. of 'beeps'	Message displayed	Meaning
0	CALL PHONE ON	The telephone mode is on.
1	CALL TEL-No 1234 -----	A request for you to enter a telephone number.
1	SEOr TEL-No E_	A request for you to enter a code number for a particular telephone number.
1	dEL TEL-No E_	A request for you to enter a telephone number that you want to delete from memory.
1	CALL DISCON 1234 TEL	Indicates that you can send a disconnect telephone message to the call line between your Radiophone and the base station
0	CHL 428 P2 CALLED	An ordinary (not telephone) selective call has been received. This example shows a call received from station 428 on channel P2.
0	CHL 428 P2 E-CALL	A telephone call has been received from station 428 containing telephone number information has been received on channel P2.



Display messages

No. of 'beeps'	Message displayed	Meaning
0	CALL Tx 4012 400 Rx 4012	A call has been received on another channel. Display shows call on channel 400 and frequencies.
0	CHL CALLED P2 Rx 12.340	An ARQ call has been received. In this example, on channel P2 the frequency is 12.340 MHz.
1	CALL No TEL prog	Indicates that no telephone numbers have been stored.
1	Store TEL-No t_ USEd	A request to store a frequently used telephone number as a single digit.
1	CHL No TEL 14 OTC	This is not an OTC channel and OTC functions do not operate.
0	SET START SETTE	Indicates that your Radiophone is switched on and in the Mute set-up mode.
1	Ant Control CHAN	Indicates that your Radiophone is switched on and in the Antenna select output mode.
1	Ant Control BAND	Indicates that your Radiophone is switched on and in the Frequency band operation mode.





System errors

No. of 'beeps'	Message displayed	Meaning
3	<p>UN-LOCK ERROR</p>	<p>Internal synthesiser is unlocked. All transmission is inhibited and the receiver is muted.</p> <p>Turn the Radiophone off and then try again. If the problem persists, the Radiophone must be returned for service.</p>
2	<p>TUNE FAULT</p>	<p>The external tuner has not completed a tune operation within five minutes.</p> <p>Turn the Radiophone off and then try again.</p>
0	<p>NO CHANNELS</p>	<p>No channels have been programmed into the Radiophone.</p>

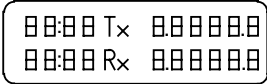
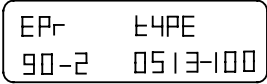

Reviewing the EPROM program content

With the Radiophone on, push and hold the On/Off button. The display will show the following test displays at three second intervals. On releasing the On/Off button the Radiophone is turned off.

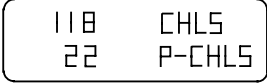
No. of 'beeps'	Message displayed	Meaning
0		Display lamp test: all segments must be on and all the indicators lit.
0		This shows the Program (EPROM) type number. (example 90-20513-100)
0		Program (EPROM) issue number. (example 4.3). Some indicator lamps will turn off.
0		The top line shows the number of channels programmed by the factory or agent, this can be up to 501. The second line shows the number of channels programmed by the user, this can be up to 99 or 89 with the telephone mode enabled.

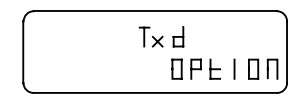
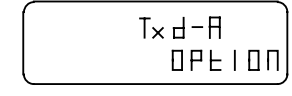

No. of 'beeps'	Message displayed	Meaning
0		<p>These displays indicate some of the options fitted to the Radiophone.</p> <p>d indicates that the Radiophone is inhibited from entering transmit frequencies from the front panel.</p>
		<p>A indicates that the Radiophone is programmed for use on the amateur band.</p>

Note: This procedure is repeated in section 4, *Reviewing the EPROM version and options*



Display messages



13. Front and rear panel sockets

Only suitably qualified personnel should use the information contained in this section. Failure to observe the stated and implied criteria could result in damage to the Radiophone.

Details are provided on the following sockets:

- microphone socket
- external alarm socket
- antenna control socket
- remote control socket.

Microphone socket

This socket is located on the front panel of the control head. It is used to connect the microphone to the Radiophone.

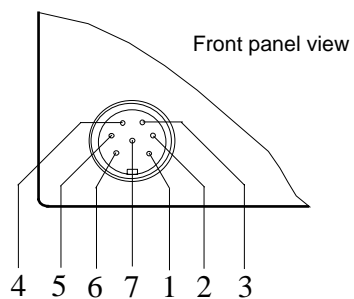

Pin No.	Designation	Pin No.	Designation
1	PTT ground	5	Speaker connection
2	PTT (active low)	6	Audio output
3	Microphone input	7	Audio ground
4	Microphone ground		



External alarm socket

This socket is located on the rear panel of the transceiver.

This facility allows an external alarm device to be connected to the Radiophone. When a selective call is detected, internal relay contacts close across pins 2 & 3.

The contacts are rated for 1A at 50V DC.

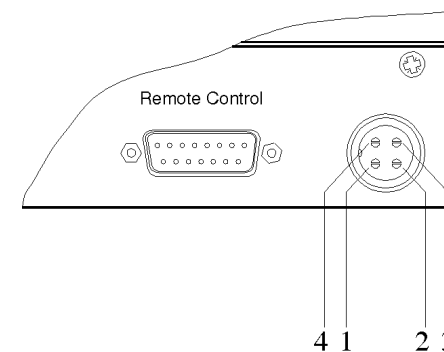

Pin No.	Designation	Pin No.	Designation
1	Not used	3	Relay contact
2	Not used	4	Ground



Antenna control socket

This socket is located on the rear panel of the transceiver and accepts the plug from the automatic tuning whip antenna. A warning label above the antenna control socket indicates **WARNING CONNECT TO 8558 ONLY.**

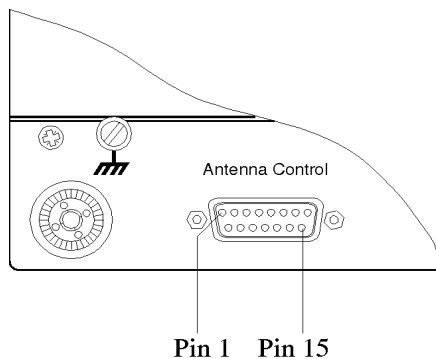

Pin No.	Designation	Pin No.	Designation
1	Channel number Bit 3 (oc)	9	Channel number Bit 1 (oc)
2	Channel number Bit 4 (oc)	10	Channel number Bit 2 (oc)
3	Disable (ground to disable)	11	Switched +12V Motor
4	Load	12	Switched fused battery voltage
5	+ 12V Scan	13	Switched fused battery voltage.
6	Motor phase 1 (oc)	14	Ground
7	Motor phase 2 (oc)	15	Motor phase 3 (oc)
8	Motor phase 4 (oc)		

(oc) = Open Collector (Active high)



Remote control socket

This socket allows the remote control head to be connected to the Radiophone.

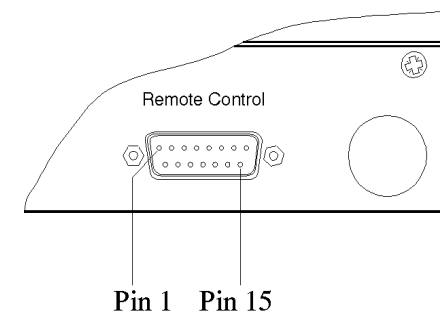

Pin No.	Designation	Pin No.	Designation
1	Loudspeaker	9	Ground
2	Remote PTT (active low)	10	Ground
3	Receiver audio input *	11	Transmit audio input (1.5V pp)
4	Power on (active low, pulse)	12	Receiver demodulator output (1.5V pp)
5	Data (I ² C Bus, 5V)	13	Receiver audio output *
6	Data line enable (I ² C Bus, 5V)	14	Interrupt (I ² C Bus, 5V)
7	Clock (I ² C Bus, 5V)	15	Switched fused battery voltage.
8	Transmit lamp		

* Special: Adjusted to suit attached equipment.



Front and rear panel sockets

14. Specification

Frequency range	Transmit: 2 to 24 MHz (CB: 27 MHz) Receive: 250 kHz to 30 MHz
Channel capacity	600. Comprising 501 pre-programmed EPROM controlled channels and 99 front panel, user programmable channels.
Transmitted power output	100 watts PEP (CB: 12 watts PEP)
CB operation	27 MHz, 40 channels SSB (USB – LSB) 12 watts PEP
Supply voltage	12V DC nominal, negative earth Reverse polarity and over-voltage protected.
Supply current	Receive (no signal): 0.4A Transmit J3E voice: 6A (average)
Size and weight	8528 transceiver (Radiophone) 270 mm W x 370 mm D x 90 mm H; 3.9 kg (includes vehicle mounting frame) 8533 control head 190 mm W x 50 mm D x 75 mm H; 0.4 kg (includes mounting bracket) Depth measurement includes allowances for rear connectors and cables.



15. Options and accessories

The following options and accessories are available for the Radiophone.

Code	Options
A	Fit amateur band transmit-receive facility (for licensed amateur radio operators).
F	Fit for continuous data transmission.
PP	Fit unswitched battery power output facility.
711	Bulkhead mounting fuse holder for transceiver DC power cord - supplied with 32 amp fuse.
712	32 amp fuse for code 711.
2036	Service manual for type 8525B/8528 series (Radiophone).



