

# Upgrading the KW2000 series of HF transceivers

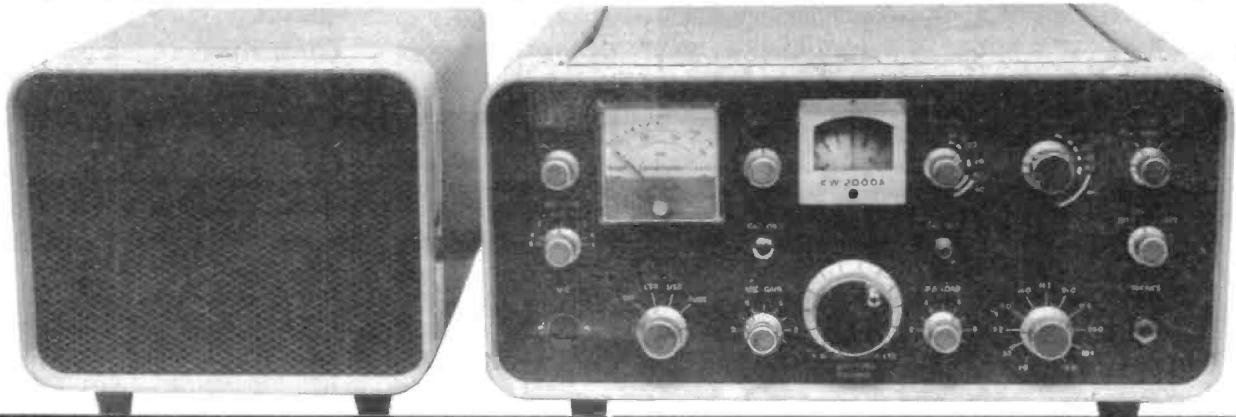

In Part 1 of this series a general description was given of the KW2000 series of HF transceivers, which represent particularly good value-for-money on the second-hand market at present. This second article gives guidance on the diagnosis of any faults which may be present, and the third article will cover the alignment procedure. Subsequent articles will give details of some of the many modifications which can be carried out to improve various aspects of the performance. Before any modifications are attempted it is strongly recommended that the test procedure to be given in this article is followed since any fault which may exist may well be more difficult to trace after modification, and it may well not be obvious whether a malfunction is due to an error in the modification or whether it already existed! It is assumed that the reader possesses a few hand tools including a *decent* soldering iron, a set of proper alignment tools, ie. hex nylon type (DO NOT USE A MATCHSTICK OR FILED-DOWN KNITTING NEEDLE AS THIS CAN BREAK THE HEXAGONAL CORES!) and a multi-range test meter (not DVM) of at least 20k ohm/volt which is able to measure up to 10M ohm resistance. A good quality signal generator is

## Part 2

By M. T. Healey, G3TNO  
and R. Charles

### Making good the wear and tear

also useful although not essential unless the alignment has been severely tampered with. A dummy load and some means of measuring RF output power (eg. an SWR meter) are also required, and a general coverage receiver is useful if the 2000 has been badly misaligned.

### Initial test procedure

In this section a complete test procedure is given which should be adopted with a newly acquired rig to verify that all sections are operating correctly before any modifications are attempted. If a fault is found at any stage during the testing it should be repaired before proceeding any further with the tests.

The causes and cures for various commonly encountered faults are given later in this article.

The transceiver should first be removed from its case by removing all four feet on the underside of the cabinet and then gently sliding the chassis forward to clear the case. At this stage it is as well to have a completely clear bench on which to work. Next the power supply and a suitable aerial system should be connected, and the transceiver switched on and allowed to warm up for 5-10 minutes. Following the list in **Table 1**, the various controls should be checked for smoothness of operation and absence of crackles or any intermittency of operation, checking through the bands on receive only from 28MHz to 1.8MHz, placing a tick in the right-hand box of **Table 1** if a control is considered to be working correctly, and noting any faults found in the centre column. There is no point in continuing until there is a complete set of ticks since the same ground may have to be covered twice if any problems are ignored at this stage. It is useful to keep the check list for future reference in case of the recurrence of a fault; this will save the repeated investigation of the same problem!

Next the transmitter's basic operation should be checked. The

aerial system should be removed and the rig connected to a good dummy load as shown in **Figure 2A**. Filament lamps should not be used as a load since their resistance changes with power level, they are inductive and they tend to radiate! The 3.7MHz should be selected and, with the MIC GAIN control at minimum, the rig is set to TUNE and tuned up as described in the handbook, that is by gradually increasing the mic gain and adjusting PRE-SELECT and PA TUNE and LOAD for maximum output. The function switch is then set to either USB or LSB, the MIC GAIN set to minimum and INT. MOX selected. This puts the rig into transmit but with no drive to the PA, so there should be no power indicated on the power output meter or SWR meter. Assuming this is so, the PA standing current can be checked, the correct value being 50mA on the KW2000A and B, and 25mA on the KW2000 which has only one PA valve. If the correct current is not observed the PA bias control, which is on the rear of the PSU chassis, should be adjusted to obtain the correct value. A useful check of the matching of the two PA valves in the KW2000A and B is to return the rig to receive by switching from INT. MOX to EXT. MOX, reset the bandswitch to 1.8MHz and tune up as before. Following the procedure given

above, the PA standing current should now be checked, the correct value in this case being 25mA (again, with no RF output).<sup>\*</sup> If this condition is not met (ie. standing current 50mA on all bands except 1.8MHz where it should be 25mA), and two PA valves are not a matched pair. The best course of action in this case is to fit a new matched pair, but it may be possible to find a valve in the junk-box which will give a reasonable match with one of the pair already fitted. As before there is no point in proceeding further until these conditions can be achieved.

Assuming that the above conditions can be met a table similar to Table 1 should be drawn up listing the remaining controls, ie. MIC GAIN, PA TUNE and PA LOAD, and these should be checked for smoothness of operation. The PRE-SELECTOR should also be checked in the TUNE mode. Any jumpiness of PA current as the MIC GAIN is varied in the TUNE mode should be noted, since the current should rise smoothly from zero up to 125mA on the KW2000A and B (and approximately 70mA on the KW2000) on 3.5MHz. If any jumpiness exists it may indicate a faulty (or dirty) MIC GAIN control. The power output under key down conditions should be checked against the figures given in **Figure 2B**, the PA current being 200mA in the case of the

KW2000A and B or 100mA for the KW2000.

### Curing problems with the controls

It is the firm opinion of the writers that any of the potentiometers which are in any way intermittent should be replaced by good quality new components rather than attempting to clean or repair them. Such a repair is unlikely to last very long, and it is worth avoiding later problems for the price of a new component.

### Cleaning

**VFO tuning control:** if this feels notchy or lumpy as so often happens the only cure is to replace the ball bearing reduction drive with a new one. On the KW2000B the reduction drive is part of the VFO tuning capacitor so the capacitor will have to be replaced as well! If the tuning of the VFO is intermittent as the tuning control is rotated, and it is difficult to net, the most likely cause is a worn tuning capacitor and again a replacement is really the only cure.

**Switches:** if stiff or rough in operation the indexing mechanism at the front of the switch should be cleaned, after which a 'trace' of light grease should be applied to ball-bearings, not forgetting to oil the shaft lightly where it passes through the bush on the front panel.

Noisy switches can almost always be cured with a good quality switch cleaner (aerosol) with its own lubricant, for example RS components contact cleaner/lubricant cat. no. 554-175 or similar. Cleaners of the type containing carbon tetrachloride should not be used as these can damage the switches and also are considered to be hazardous to health.

When cleaning switches, a small amount of cleaner should be applied to each wafer in turn, at the same time operating the switch from position to position. This actually helps the cleaner to do its job. It should be ensured that the power is off!

After switch cleaning some time should be allowed to elapse before switching on, as the switch cleaner will cause drift of the RF circuits around the band-switch.

<sup>\*</sup>The reason for the drop in standing current is that one PA valve is switched out of circuit on 1.8MHz to reduce the output power.

Table 1

CONTROL	FAULT IF ANY	TICK IF OK
On/Off Sideband Select and Tune		
AF Gain		
RF Gain		
VFO Tuning		
IRT Tuning		
IRT, IIT etc Switch		
Pre-Selector Tuning		
Band Select		
Cal. on Button		
Cal. Set		

## Failure to receive or poor receive

If during the preceding checks the receiver is found to be poor or inoperative, checks will have to be made to determine if the fault is in

the AF, IF, mixer or RF stages, or, indeed, the power supply.

REMEMBER THAT THE VOLTAGES THAT EXIST IN THIS TRANSCEIVER CAN BE LETHAL, SO TAKE GREAT CARE, AND

REMOVE THE MAINS PLUG FROM ITS SOCKET IF YOU NEED TO SOLDER COMPONENTS, ETC. SWITCHING THE TRANSCEIVER OFF AT THE FRONT PANEL IS NOT ENOUGH AS MAINS VOLTAGE IS STILL PRESENT WITHIN THE TRANSCEIVER AND POWER-SUPPLY CABINETS UNDER SWITCH-OFF CONDITIONS.

Assuming, first of all, that the receiver is totally dead, the following procedure should be adopted:

1. Switch on and observe that all valve heaters are glowing.
2. If not, switch off and check the heater of the offending valve or valves for continuity on the ohm range of the multimeter. (There should be only a few ohms across the heater pins.) If just V11 (VFO) and V10 (HF oscillator) are not glowing it is as well to remember that these two valves have their heaters supplied separately from all the other valves, and a check should be made on the supply voltages at the valve pins of the HF oscillator V10. (It is impossible to measure the heater voltage actually at the pins of V11 VFO as these are in the VFO compartment.) Replace any valves with open circuit heaters with new replacement valve(s). (See VFO footnote Table 2).
3. If, however, only a few valve heaters are glowing, and possibly very brightly, switch off immediately! Remove mains plug from socket! Now check the wiring to the multiway plug/socket from the power supply as these are rather prone to breakage, especially in the plug.

Table 2

Voltage checks. Receive condition. Control settings. LSB, Bandswitch, 3.5MHz. AF Gain, Midway. RF Gain Minimum. EXT MOX.

VALVE	PIN NUMBERS									NOTES
	1	2	3	4	5	6	7	8	9	
V20	+	150			+	150	0	—	—	IF voltage low or high check V20, R96, R100
V17	0	20	0	50Hz 6.3	50Hz 12.6	225	240	1	70	IF voltage on Pin 2 low, check, V17, T <sub>1</sub> , Primary, R100, C151 IF voltage Pin 2 high check V17, R93, C125 IF voltage pin 9 low, check, V17, R92, C125 IF voltage pin 9 high, check, V17, R94, RV95 slider to chassis
V16	100	-.5	0	0	0	100	0	3.5	50Hz 6.3	IF voltage pin 1 or 6 low check voltage at V20, RFC9, R13
V15	175	0	A/C 2.6	A/C 6.3	6.3	135	-1	.6	A/C 12.6	IF voltage pin 6 high/low check V15, R82, R81, C109, C127
V14	0	-.3	A/C 12.6	A/C 6.3	4	—	-.43	—	—	IF voltage pin 5 low, RX gain will be low, check V14, R68, R69
V13	0	—	A/C 6.3	A/C 12.6	200	135	3.5	—	—	IF voltages high/low check V13, R70, R72, R71, C105, C104, IFT4
V12	0	—	A/C 6.3	A/C 12.6	215	3.0	—	—	—	IF voltages high/low check V12, R22, C22, C97, C98, R66, IFT5
V11	115	0	7.8	A/C 6.3	A/C 12.6	72	1.2	4.5	4.2	VFO See note below. But check V11 and voltage from V20
V10	Approx -2.5	0	A/C 6.3	0	220	0	170	—	—	IF voltages high/low check V10, R51, RFC7, R49, C71, C75, C193
V9	-1	1.2	A/C 6.3	A/C 12.6	235	52	0	—	—	IF voltages high/low check V9, R46, R47, R48, IFT2, C27, R28. Also V4 if pin 5 V9 low
V19	0	1.2	A/C 6.3	A/C 12.6	240	52	0	—	—	IF voltages high/low check V19, R114, R115, R116, R117, R221, C22, C134, C135, C136, Mech. filter
V6	.35	-23	.35	A/C 6.3	0	0	235	35*	0	*Voltage pin 8 depends on band selected. IF voltages high/low check R39, R40, R123, R36, APC1, R35, V6, C37

Note: All voltages  $\pm$  10%

Note: All voltages within the VFO are difficult to measure and a 9 pin plug/valve holder with suitable test points on it and interposed between valve and VFO. If any resistors are found defective in the VFO it is best to replace them all.

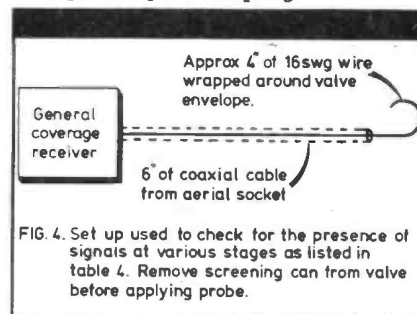

FIG. 4. Set up used to check for the presence of signals at various stages as listed in table 4. Remove screening can from valve before applying probe.

Assuming that all valve heaters are glowing and the receiver is still dead, look at the voltage stabiliser V20. This should be seen to glow a purple colour. If not, most probably either V20 is defective or no HT is being supplied from the PSU. Check leads/plugs/back to PSU and

fuses. Invert the transceiver chassis and measure from the low voltage HT rail to chassis (the HT rail is wired in red). A reading of 250V should be obtained. If no voltage is present check the fuses in the PSU. If the heaters are glowing and HT is present but the receiver is still dead check the voltages on the pins of the receiver valves against the values given in Table 2, working from the output stage back to the RF stage. A simple check on the output stage (V17) is to switch on and, with the multimeter set to ohms and one probe to chassis, connect the other probe to the G1 pin of the pentode section (pin 3). A loud pop should be heard as the probe is connected and disconnected from the grid. If not, and all voltages around V17 are correct, check the PHONES socket as this incorporates a switch which disconnects the loudspeaker when headphones are used, and this sometimes gives trouble through wear and tear. Another point to be borne in mind is that, due to a fault in the change-over circuits, the rig may be permanently in transmit. This can be checked by measuring the voltage on pin 6 of V21 (VOX amplifier), which should be approximately 240 volts if the rig is in the receive mode; if it is much lower the 2000 may well be stuck in transmit. Removing V21 from its socket briefly will prove the point, as the rig will then revert to receive. However, do not leave V21 out for more than a few seconds as this unbalances the heater voltages to the other valves. If removal of V21 does bring the receiver to life, and replacement by a new valve does not cure the fault, check all the resistors on pin 7. These resistors are of high value and have a nasty habit of going open circuit. Also check the capacitors in the circuit for leakage. If the receiver persists in remaining dead proceed through the voltage checks of Table 2. The correction of any problems found during the voltage checks will normally cure even the most stubbornly deaf 2000 unless, that is, someone has had a go at the alignment and left it miles out of adjustment! It is worth noting that the RF/IF alignment of an untouched KW2000 receiver will remain extremely stable over a period of many years. At worst a slight "tweak" may be required on the 10, 15 and 20 metre bands only, and then only if com-

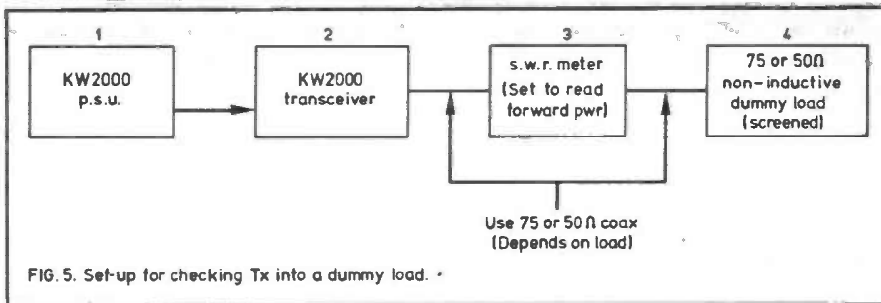

FIG. 5. Set-up for checking Tx into a dummy load.

Table 3

Voltage check. In TX condition. Control settings — Band 3.5MHz. Mic gain — Minimum, LSB, Int Mox, Mic connected.

VALVE	PIN NUMBERS									COMMENTS
	1	2	3	4	5	6	7	8	9	
V1	70	0	0.4	0	0	90	0	0.8	A/C 6.3	If pins 1 or 6, low, V1, R3, R4, C2, C145, C3.
V2A	—	—	—	0	0	150	0	2.6	A/C 6.3	If pin 6 low check, V2, R12, R11, R10, C8.
V3	1.0	0	1.0	A/C 6.3	A/C 12.6	0	45	50	0	If pin 7 or 8 low, check R18, R19, R21, (++)
V4	170	0	1.5	A/C 6.3	A/C 6.3	170	0	1.45	A/C 12.6	If voltage pins 1+6 low check V4, R28, C23.
V5	210	0	1.7	A/C 12.6	A/C 12.6	210	0	1.7	A/C 6.3	If voltages pins 3+8 low check V5, R32, R26.
V8	0	A/C 6.3	225	0	-50	0	0	0	TopCap 750	If no volts on Top Cap check RFC4, HT fuses
V23	0	6.3	225	0	-50	0	0	0	TopCap 750	in P.S.U. wire broken in multi-way connector on back of KW2000

Note: Most of the faults found in KW2000 series on TX i.e. low drive or intermittent drive were caused by R18, R19, R21, going very high in value due to ageing.

(++) = These resistors are often the cause of low/intermittent TX drive.

Table 4

STEP	Fit sniffer to:	External RX Frequency	Checking
1	V16	455KHz approx	Carrier OSC. See xtals in KW2000 for exact frequency
2	V11	Depends on VFO setting. 2.5MHz to 2.7MHz	Exact frequency depends on KW2000 VFO setting. Checks VFO
3	V4	2.995 to 3.155MHz Depends on VFO setting	Check 1st TX mixer to see if some output is present ON TX ONLY i.e. 455KHz + VFO
4	V5	Depends on KW2000 VFO and band selected. But on frequencies dialled up on KW2000.	Checks 2nd TX mixer to see if some output is present ON TX only
5	V7	As above	Checks some output is present from driver stage
If signals are present in steps 1-5 there is no point in doing step 6.			
6	V10	Tune RX to LF edge of band selected on KW2000 + 3.155MHz eg. Band selected on KW2000 = 3.5MHz + 3.155MHz = 6.655MHz etc.	This checks V10. HF oscillator is working on all bands.

ponents such as capacitors or resistors have been changed in the RF stage or mixer. However, the complete alignment procedure will be given in the next article for anyone who wishes to carry it out.

If the receiver is working it is not normally very difficult to get the transmitter going, so if performance is poor on transmit it is worth checking the stages which are common to both receive and transmit paths, namely the VFO, HF oscillator and carrier oscillator. This is far easier to do on receive as you can hear what is happening.

### Faults on transmitter

In the case of a transmitter fault the voltages in Table 2 should be checked as well as those in Table 3 since a fault in the receiver can reduce the transmitter drive, parts of the signal path being common to both modes. There are, however, a few conditions in which it is inadvisable to leave the rig while checking the receiver performance:

1. No control of PA bias, ie. PA hard on.
2. Blown HT fuse to PA anode circuits as this can damage the screen grids of the PA valves.

These dangerous conditions can be discovered rapidly in the following manner:-

**1. No control of bias:** set the rig to INT MOX and note the standing current on the front panel meter. if this is high, adjust the bias control on the PSU. If it is found that the bias control does not affect the current SWITCH OFF IMMEDIATELY and check the grid bias components for the PA including the valves and C48 which, if short circuit, puts HT onto the control grids. The wiring to the multi-way plug on the back of the KW2000 should also be checked for broken wires under the clamp.

**2. Blown HT fuse in anode circuit:** this can be caused by faulty PA valves, no bias on control grids, incorrect tuning, or instability (incorrect neutralising can cause the PA to go unstable — see next article). If a fuse blows persistently the fault should be investigated at once. The fuse should NEVER simply be replaced by one of a higher value as this can cause expensive damage! A blown HT fuse is often indicated by a sudden drop in PA standing current to virtually zero (the meter reads PA cathode current so there

will still be a slight reading, caused by screen current, even with no anode volts present in transmit mode).

There is one fault on the transmitter which is obvious without too much trouble, namely absence of CW sidetone and output power, and VOX inoperative with key down. The rig will also produce no output in the TUNE mode. This is due to the tone oscillator V15 failing to oscillate. A check should be made either in TUNE or with the key down and with the receiver AF gain control at about one third, when the tone should be heard in the loudspeaker. If not check V15, R87, R88, R89, R90, R91, C4, C119, C120, and C121. The tone oscillator can be very 'touchy' if these components have aged.

Do not proceed to check the transmitter without the tone oscillator as it is used to provide drive during tune up and on CW. Without it, it is very difficult to tune up correctly!

Assuming that the proceeding tests have been carried out and any faults found have been repaired, the transceiver should now show signs of life on both transmit and receive unless, of course, the alignment has been tampered with. There are a few simple tests which can help if there is still a problem such as no transmit output or low receive sensitivity. A general coverage receiver can be used to listen for signals from the various parts of the circuit, lightly coupling the receiver to the KW2000 as shown in Fig. 4. Table 4 gives details of what should be observed in each case. Note that in steps 3 to 5 the transceiver should be set to TUNE with the MIC GAIN

turned fully up. However, the PA current (if any) should be monitored and not allowed to rise above 100mA at any time. If the current is too high reduce the MIC GAIN. The information gained from Table 4 can be used to provide clues to the location of the fault. For example, if signal is present in steps 1 and 2 but not in step 3 it is possible that there is a fault in or around V3 (transmit IF amplifier). This means that no signal is arriving at the grid of the first transmit mixer V4, so there is no mixer output. Alternatively, V4 may not be mixing due to valve or component failure. If that is so, re-check those stages very carefully using the tests given in Tables 2 and 3. The tests of Table 4 will at least identify the area in which the fault is located.

Once all the tests in Tables 1 to 4 have been carried out the rig should be working well enough for the alignment to be checked. However, this will only be necessary if:-

1. The rig has been tampered with.
2. Max receive gain and max transmit drive do not coincide when adjusting the pre-selector tuning.
3. Components have been replaced in a particular stage, in which case it should only be necessary to re-align the stage concerned, or at worst the stages before and after.
4. If some of the modifications to be described later have been carried out.
5. It is desired to get the best results possible!

**The complete alignment procedure will be given in the next article.** ●

**Table 5**

Approximate power  $\pm$  10% output to be expected  
Key down in LSB or USB

KW2000 A/B	KW 2000	Measured output power (Yours)	Band
25 watts*	25 watts*		1.8MHz
100 watts	50 watts		3.5/3.7MHz
100 watts	50 watts		7.0MHz
100 watts	50 watts		14.0MHz
85 watts	46 watts		21.0MHz
80 watts	40 watts		28-28.6MHz

Measured on my KW2000A on bird thro' line watt-meter into 50

Measured on friends KW2000 on Bird thro' line watt meter into 50

Power output figures are included only to give a rough guide as to what to expect.

\*Reduced HT to P/A by switch on P.S.U.