

Upgrading the KW2000 series of HF transceivers

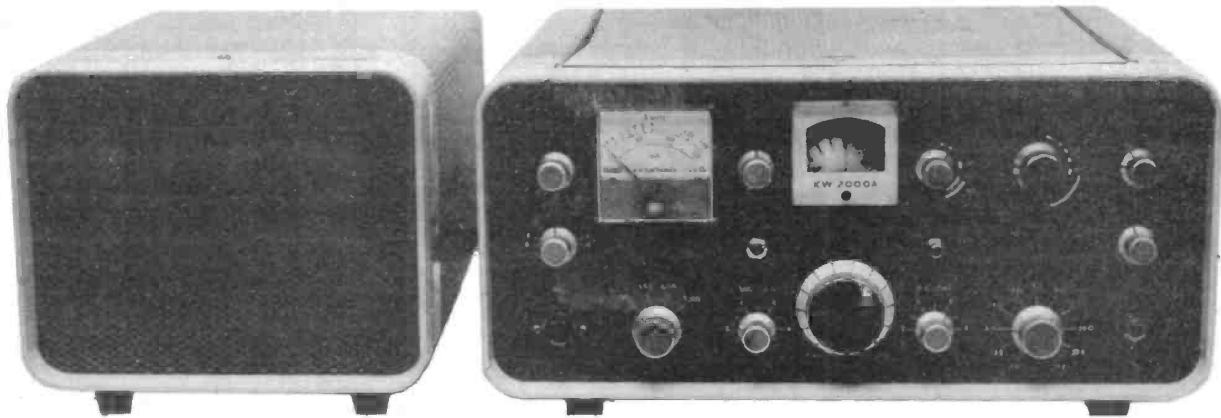

Part 3

Alignment procedure

by M.T. Healey, G3TNO
and R. Charles

The previous articles in this series have dealt with the location of faults in the KW2000 series of HF transceivers. If the procedure given has been followed it is likely that the rig will now be working reasonably well. This article describes the procedure to be adopted necessary to realign the transceiver.

Let's start with a caution: In the majority of cases, alignment will probably not be necessary, and if the rig seems to be operating satisfactorily it is best left alone! Having decided to tackle the job, the following tools should be available before beginning:

1. Hexagonal trimming tool, nylon/plastic.
2. Acetone to dissolve the coil

sealing compound (nail varnish remover is suitable).

3. Clear nail varnish to lock to cores.
4. Dummy load — filament lamps

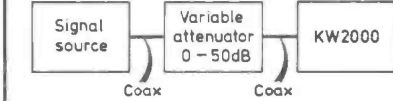

FIG.1. Typical test set-up for Rx alignment.

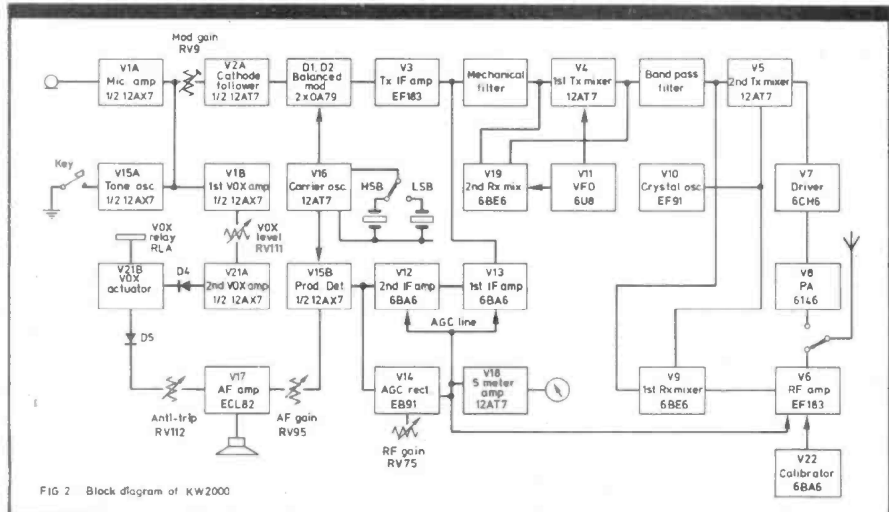

FIG.2. Block diagram of KW2000

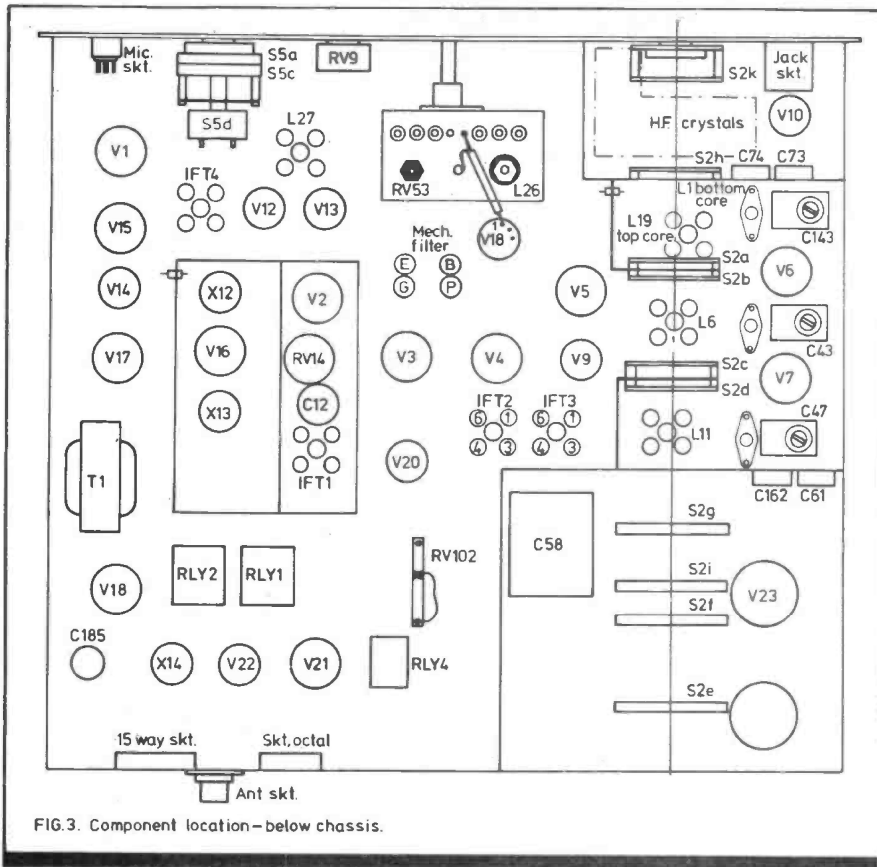

FIG. 3. Component location—below chassis.

should not be used as they are inductive, and their impedance changes with temperature.

5. Means of indicating RF power, eg. 'Thru-line' wattmeter or SWR bridge.
6. Swamping tool consisting of a 0.01 uF 400v capacitor in series with a 1k ohm, 1/2 W resistor.

If the rig is a long way out of adjustment the following additional items may be required.

7. Signal generator, or some other means of producing a 455kHz signal.
8. Band edge markers, ie. signals at 1.8MHz, 3.5MHz, etc.
9. Variable attenuator 0-50dB.
10. A general coverage receiver is useful for checking VFO, crystal oscillator frequencies, etc., and also for monitoring the final completed equipment on transmit.
11. RF milivoltmeter with probe.

The following instructions may not all need to be followed. It may be, for example, that the receiver is performing well but the transmitter suffers from low drive on one band only. In this case only part of the procedure need be carried out but

BEWARE! Adjustments carried out to, say, the 28MHz coils will affect the alignment on 21MHz and, to a lesser extent, on 14MHz, so make sure that adjustments carried out to the alignment on the higher frequency bands have not drastically upset the alignment on the lower bands. The rig should be allowed to

warm up for at least 15 minutes before any adjustments are made.

Checking 100kHz calibrator.

Tune a spare receiver (the family portable will do) to the BBC Radio 4 transmission on 200kHz, and place it close to the rear of the KW2000 adjacent to V22 and X14. Press the calibrator button on the KW2000, and adjust the coupling between the external radio and the rig until a satisfactory beat-note is obtained. The lower this is in frequency, the nearer the calibrator is to 100kHz. Adjust C158 to obtain zero beat on the external receiver.

Alignment of 455kHz IF stages

It is assumed that the receiver section of the KW2000 is now working to some degree and showing some signs of life. If it is totally dead, go back to the voltage checks listed earlier, as slight misalignment will not make the receiver totally dead.

The rig should be set up as in Fig. 1, with the RF gain at maximum and the AF gain midway. Tune the receiver to a stable signal (the author uses a harmonic of the shack frequency standard), and adjust the tuning so that the signal is in the centre of the passband (see Fig. 2). Adjust the core of L27 and the upper and lower cores of IFT4 for maxi-

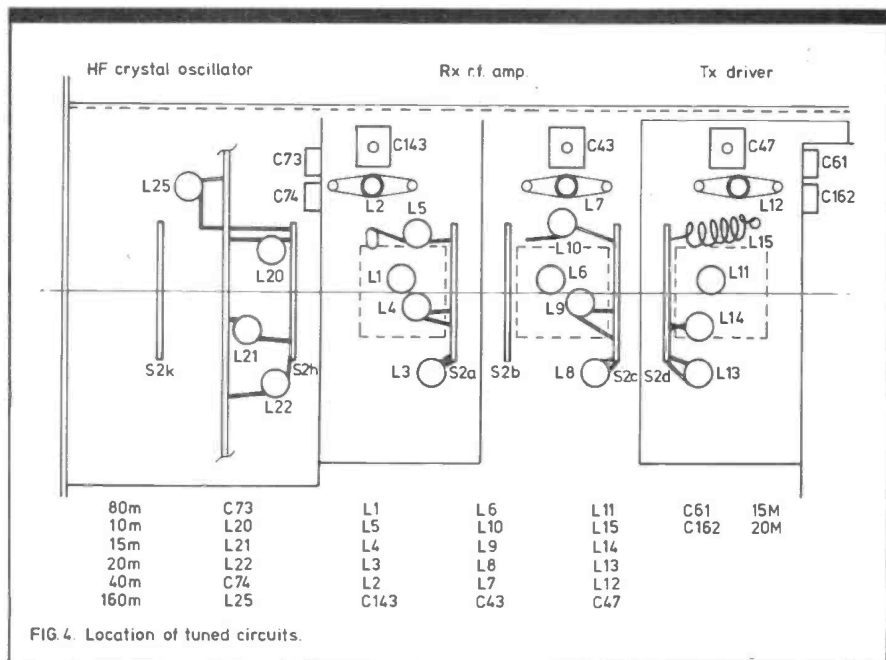

mum S-meter reading, reducing the level of the input signal as the receiver comes into alignment so that the meter does not read above S5. Repeat these adjustments until no further improvement can be obtained. Fig. 5 shows the location of the tuned circuits concerned. It is important to use the minimum possible signal level for alignment purposes, since with high levels, the peak of the adjustment may be masked due to AGC action or, in extreme cases, limiting!

If the receiver is a long way out of alignment it may be necessary to inject a 455kHz signal into the input of the second mixer V3 (pin 2) via a 0.01 uF capacitor.

VFO alignment

Set the KW2000 to the 3.5-3.7MHz band, tune to 3.5MHz and peak the preselector, using the internal calibrator as a signal source. Ensure that the IRT is turned off. Tune the VFO to 000, 100 and 200 in turn and look for zero beat and accuracy of the dial indication. If errors exist, proceed as follows:

1. Set VFO to 000 and switch IRT on. Set IRT tuning accurately to 0.
2. Using an insulated probe (e.g. a knitting needle), adjust C80, which is accessible via a hole in the top of the VFO unit, for zero beat with the calibrator signal.
3. Reset VFO to 200. Adjust the core of L26, which is on the lower side of the VFO, for zero beat with the calibrator signal. See Fig. 3 for the position of L26.
4. Repeat steps 1 to 3 until the calibration is correct at 000, 100 and 200.
5. Set VFO to 100. Switch IRT off and adjust RV53 for zero beat with the calibrator signal. See Fig. 3 for position of RV53.

If the VFO is a long way out of adjustment a band edge marker signal at 3.5MHz may be needed to identify which of the harmonics of the calibrator you are tuned to. This marker signal should be injected into the aerial socket of the KW2000.

USB/LSB switching

Set the KW2000 to 3.6MHz on USB with the IRT off, and tune to zero beat with the calibrator signal.

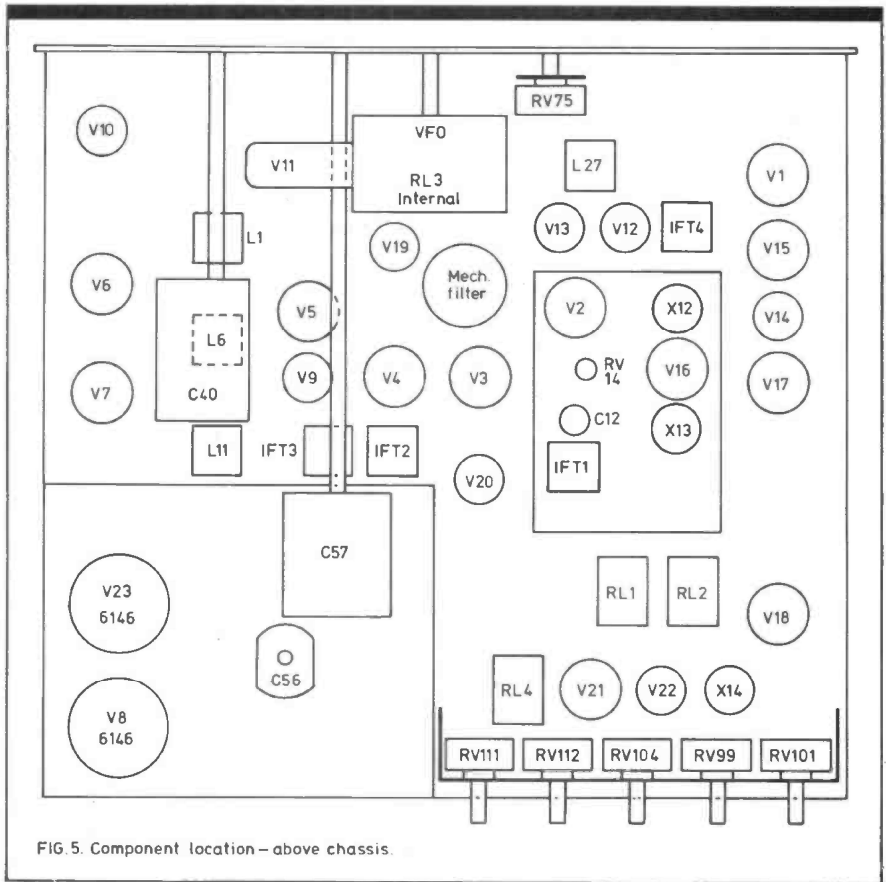
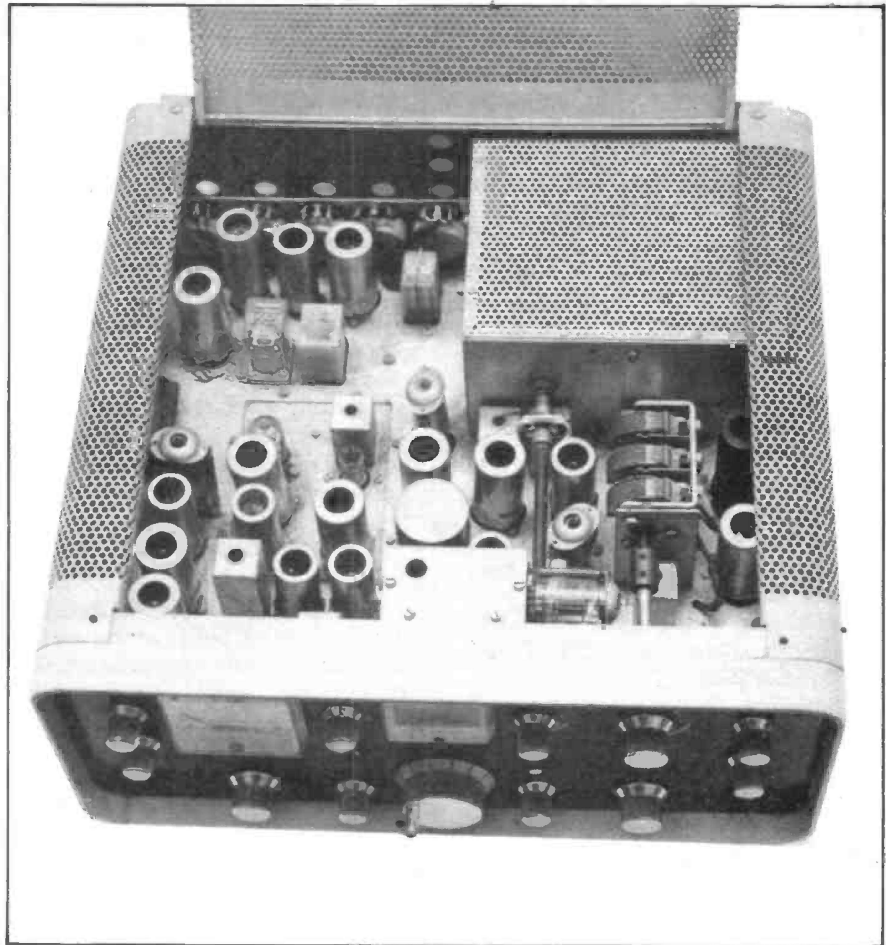

FIG. 5. Component location - above chassis.

Now switch to LSB, and, if zero beat is not obtained, adjust the link on L28, which is accessible through a hole in the side of the VFO, for zero beat. Re-check for zero beat on USB and then LSB, adjusting main VFO tuning on USB and the link on LSB, until zero beat is obtained in both positions.

Adjustment of wide-band coupler

Tune the receiver to 3.6MHz and inject a signal at 3.6MHz into the aerial socket.

2. Connect the swamping tool between pin 4 of IFT2 and chassis (see Fig. 3 for location of IFT2). Adjust lower core of IFT2 for peak on S-meter, reducing input signal if necessary to keep reading below S5. **SWITCH OFF KW2000.**
3. Connect swamping tool between pin 6 of IFT2 and chassis. Switch rig back on, and adjust upper core of IFT2 for peak on S-meter. **SWITCH OFF.**
3. Connect swamping tool between pin 4 of IFT3 and chassis. Switch on, and adjust lower core of IFT3 for S-meter peak. **SWITCH OFF.**
4. Connect swamping tool between pin 6 of IFT3 and chassis. Switch on, and adjust upper core of IFT3 for S-meter peak. **SWITCH OFF.**
5. Repeat steps 1-4 in that order until no further improvement can be obtained.

NB It is important to switch off between steps in the above procedure as there is 250 volts HT on some of the IFT pins mentioned above!

Receiver front — end alignment

The following points should be remembered when aligning the front-end:-

1. As the receiver comes into alignment the input signal should be reduced to keep the S-meter reading below S5. For the final 'touch-up' below S3 is preferable.
2. Use acetone to free the cores of the inductances without formers. After freeing, allow at least half an hour for the coils to

dry out before commencing alignment.

3. Set pre-selector control to just short of the LF edge of the appropriate band marking on the front panel, except on 160m, where it should be set to the centre of the band segments.
4. **Table 1** gives the sequence of adjustments to be followed, and **Fig. 4** shows the position of the various tuned circuits. Always tune to the first peak arrived at by screwing the tuning core into the coil, ie. nearest the top of the coil former for the upper core; nearest the lower edge of the former for lower cores.

Alignment of IF trap

Set KW2000 to 3.5MHz and inject a low level 3.5MHz at the aerial socket. Set RF gain to maximum AF gain midway, and tune the pre-selector for maximum signal. Now remove the 3.5MHz signal and inject a 3.155MHz signal to the aerial socket; tune L19 for *minimum* signal.

An alternative method, which can be used if no signal generator is available, is to set the controls as above and connect the rig to an aerial. If the pre-selector is rotated clockwise from the 80 meter peak and the VFO is tuned HF by a few kHz non-amateur signals should be heard. Having tuned to such a signal, adjust L19 for minimum signal level. Note that L19 is on the same former as L1, but is the upper core whereas L1 is the lower. After tuning L19, retune rig to 3.5MHz and retune L1 and L6 for maximum signal.

4.190MHz trap

Set KW2000 as above except for the frequency which should be 3.8MHz. Inject 4.190MHz to aerial socket of rig. Move VFO back and forth a little to locate the signal and adjust L29 for minimum signal on S-meter.

Transmitter alignment

The transmit and receive alignment have deliberately been separated since it has been found easier to get the receiver going first. When adjusting the transmitter alignment it is important that, prior

to aligning the driver stage tuning, the pre-selector control is peaked for optimum on receive and is then left untouched whilst the PA grid circuit and the neutralising are adjusted.

The rig should be set up as shown in **Fig. 6** and switched to TUNE. The MIC GAIN should then be set to give a PA current of 50mA or less, and the PA tuned for maximum output into the dummy load. The PA grid coil is then adjusted for maximum PA current, reducing the MIC GAIN as necessary to keep the PA current below 100mA. After this, the neutralisation is checked, and the PA grid circuit readjusted if it has been necessary to alter the neutralisation setting, since this will affect the tuning of the grid circuit. Neutralisation adjustment is not necessary on 7, 8.5, and 1.8MHz. **Table 2** gives the sequence of adjustments, and **Fig. 4** shows the position of the components concerned.

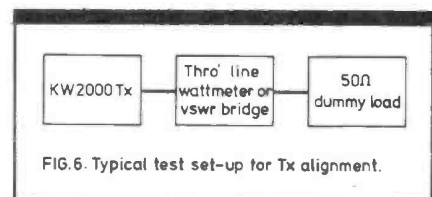

After alignment has been completed and before re-locking the cores in the various tuned circuits, it is as well to re-check the transceiver performance by giving it an on air check. The following should be noted:

General receive performance
Transmitter drive

The transmitter should not have any signs of instability or poor neutralisation.

It is also important to note that the setting of the pre-selector for optimum receive performance should coincide with that giving maximum transmitter drive.

HF crystal oscillator alignment

The tuned circuits associated with the HF crystal oscillator are very stable even over a period of years, and hence very rarely require adjustment. However, if alignment is required, procede as follows:-

1. Connect an RF milivoltmeter to

- the junction of C70 and C69.
- Loosen the cores of the coils with acetone, and allow at least half an hour for them to dry out.
 - Adjust as in **Table 3** with KW2000 in receive mode. Fig. 4 shows the coil locations.

Carrier balance adjustment

Connect KW2000 to a dummy load, switch on and allow at least half an hour for warm up. Tune rig to 3.6MHz. Tune up and then switch to LSB and select INT MOX. Set MIC GAIN to minimum. Tune a second receiver to 3.6MHz when a signal should be heard. Reduce the level of this signal to as low a level as possible by adjusting RV14 and C12 in KW2000 for minimum carrier. These two adjustments interact, and so they should be adjusted alternately until no further improvement can be obtained. Having done this, switch to USB and compare the carrier level with that obtained in LSB. It has been found that with some KW2000s a compromise has to be made between the two as regards carrier balance.

S-meter adjustment

KW Electronics state in their handbook that with a signal input of 50mV at 3.6MHz the S-meter should read S9, and with 5mV it should read S9+40dB. To set the meter for these conditions proceed as follows:-

- Set RV102 to the centre of its travel.
- With no signal input, adjust S-meter to zero using RV101.
- Inject a 3.6MHz signal at 50uV into the aerial socket, and tune pre-selector for maximum S-meter reading.
- Adjust RV99 so that the meter reads S9.
- Increase the input signal to 5mV and adjust RV102 so that the meter reads S9+40dB.
- Remove input signal and re-adjust meter to zero with RV101.
- Repeat the above procedure until readings are correct at all three specified levels.

Now that the KW2000 is working correctly it is safe to start carrying out modifications. Next month's article will give details of some of these.

RX ALIGNMENT (RF STAGES)

Table 1

Input frequency	Adjust for max 'S' meter readings
28.1	Adjust L5, L10 (Repeat 2-3 times)
21.1	Adjust L4, L9. <i>Note:</i> If L4 has no core. Rock pre-selector back and forth. Peak with L9 ONLY
14.1	Adjust L3 and L8 (Repeat 2-3 times)
7.1	Adjust L2 and L7 (Repeat 2-3 times)
3.6	Adjust L1 and L6 (Repeat 2-3 times)
1.9	Adjust C143 and C43 (Repeat 2-3 times)
NOTE	Always align RF stages HF bands first. Never in reverse order!

TX ALIGNMENT

Table 2(a)

Frequency	Adjust for maximum drive	Neutralising adjustment
28.1	L15 Repeat this adjustment if neutralising has been adjusted.	Max output from P/A should be at 'Dip'. If max o/p is obtained with P/A current meter, then reduce valve of C56. If max is on HF side of Dip, increase value of C56 (neutralising capacitor).
21.1	L14 Repeat this adjustment if neutralising has been adjusted.	Note: If max o/p from P/A is at 'Dip', if max o/p is LF of Dip. Increase C61. If max o/p is HF of Dip. Decrease C61
14.1	L13 Repeat if neutralising has been adjusted	Note: If max o/p from P/A is at 'Dip'. If max o/p is LF of 'Dip' increase C162. If max o/p is HF of 'Dip' decrease C162.

Table 2(b)

Frequency	Adjust for max drive
7.1MHz	Adjust L12
3.6MHz	Adjust L11
1.9	Adjust C47

Table 3

Band	Adjust for max reading on RF mA meter
28.4	L20
21.0	L21
14.0	L22
7.0	C74
3.5	C73
1.8	L25