

Upgrading the KW2000 series of HF transceivers

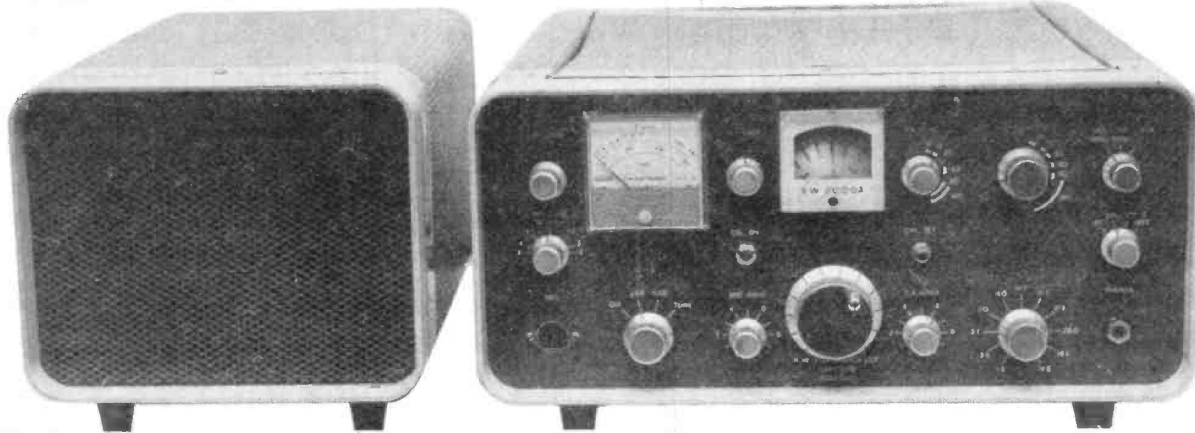

If you have followed the procedure given in previous articles your KW2000 should now be working reasonably well. You may well now feel that it is worth while making some improvements to the rig, and adding some features that it does not possess in its standard form. A possible list of 'things that would be nice to do' might be as follows:

1. Stop the VFO drifting with changing mains voltage, due to the heater voltage of the VFO changing.
2. Improve the receive sensitivity on the 21 and 28MHz bands, which is not as good as more modern designs.
3. Improve the selectivity on CW, since the passband, which is designed for SSB, is uncomfortably wide for CW, particularly under contest or crowded band conditions.
4. Improve the note on CW transmit. The KW2000 has a very distinctive sound on CW that is less than perfect to the CW purist.
5. There are no facilities for any of the WARC bands, and on 21 and 28MHz the whole of the band is not covered.
6. Cross-modulation performance is poor, particularly on 7MHz.
7. It would be useful to be able to vary the transmit power on SSB and

Part 4 Modifications

By M.T. Healey, G3TNO,
and R. Charles

CW properly, i.e. by some other means than using the MIC GAIN control.

The methods by which the writers have improved the above features are described below. However, there are many alternative ways of tackling all of them, and the way in which any individual tackles them will, of course, depend on his personal preference, and the contents of his junk box!

VFO drift

Whilst most sections of the KW2000 are comparatively insensitive to supply voltage variations, the VFO V11 and HF crystal oscillator V10 tend to change in frequency as their heater voltage, and hence cathode temperature, is

varied. Because of this their heaters are not connected to the main 12V heater system of the transceiver, but are brought out to a separate pin, pin 12, on the multiway connector, and the mobile PSU was designed to provide a stabilised 6.3V supply for this so that the frequency did not vary with engine speed. However, the manufacturers did not consider such a refinement necessary for base station operation and, as can be seen from Fig. 101, the supply to pin 12 is simply derived from the main 13V heater supply via a dropping resistor R9. This means that variations in mains voltage can cause variations in frequency, which can be annoying especially if using the rig with a narrow CW filter as described later.

It is comparatively easy to modify the power supply to provide the necessary stabilised 6.3V supply for V10 and V11, and one way of doing this is shown in Fig. 102. This has the additional advantage of providing an unstabilised +18V supply which can be used to derive stabilised supply voltages for various bits of additional circuitry, such as the pre-amplifier associated with the CW filter described later. It can be seen from Fig. 101 that the LT supply is derived from a 13V 5A winding on

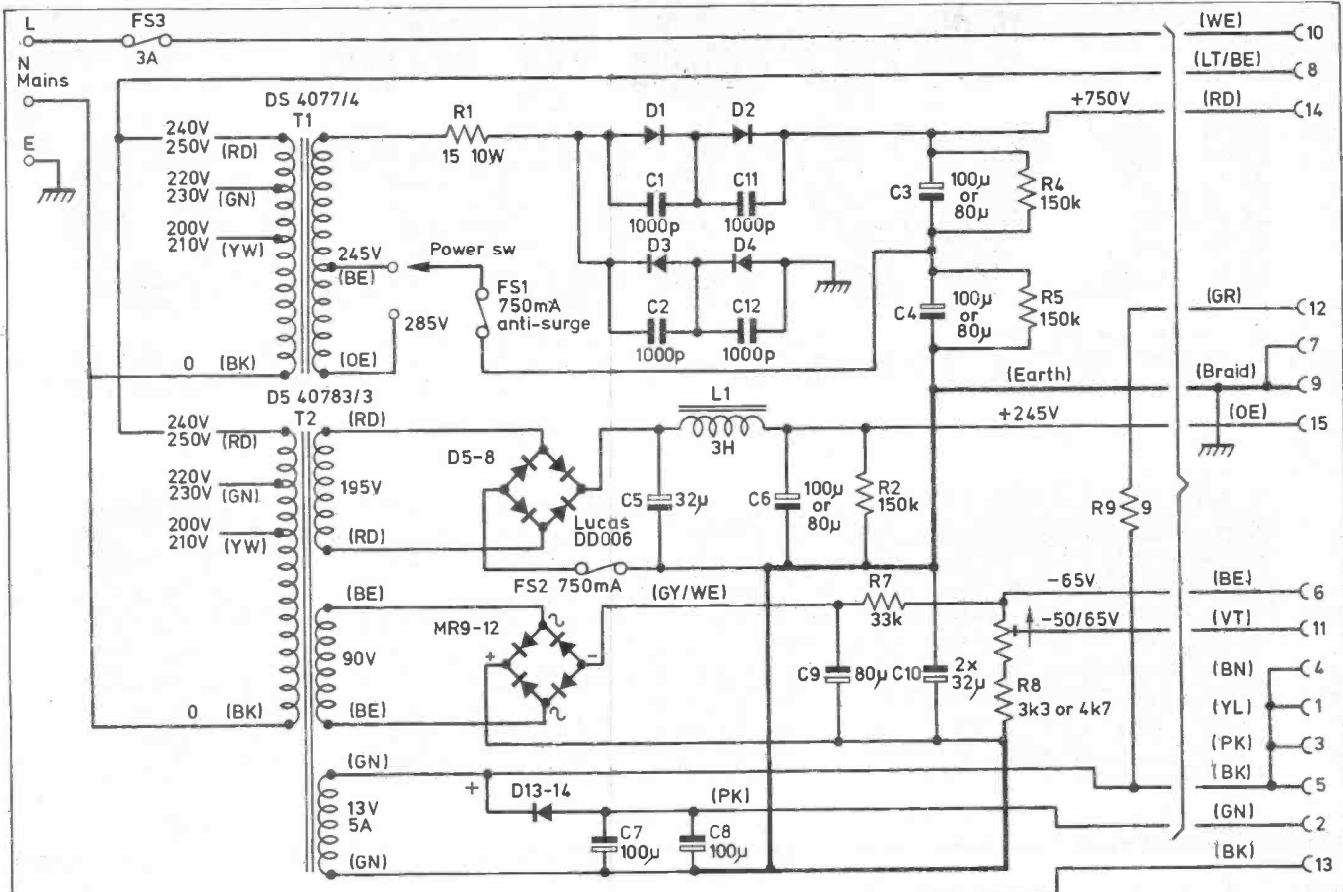

FIG. 101. Circuit of KW2000A power supply.

T2. The voltage from this winding is also half-wave rectified by D13/14, and smoothed by C7/8 to provide a DC supply for the relays. The first step in the modification process is to reverse the rectifier and remove C7/8. The current rating of the diodes should be checked and, if they are not 2 Amp types, they should be replaced by a single 2 Amp diode such as a 1N5401. In the case of one of the writers it was found that the rectifier was in fact a single 40266, which is quite adequate. C7 and C8 are now replaced by a single 5000 F 25V capacitor, mounted horizontally between T1 and T2 under the chassis. R9, which is a large ceramic disc resistor mounted on the side of the chassis, is removed and the hole in the chassis used to mount a tagstrip which will carry most of the circuitry of the new regulator. The 7805 integrated circuit is mounted alongside the tagstrip; a mica washer and insulating bush must be used since the earth tag of the IC, which is internally connected to the cooling tab, is not connected to earth in this case. The circuit is

wired up as shown in Fig. 102.

As a result of this modification the heaters of V10 now receive a stabilised 6.3V supply, and 18V DC is available from pin 2 of the multiway connector for operating other circuits. In practical terms, the frequency of the transceiver should now remain stable once the warm-up period of about 20 minutes has been completed.

Improving receive sensitivity

The simplest way to improve receive performance on 21 and 28MHz is to fit a 3-30pF trimmer across the un-decoupled cathode

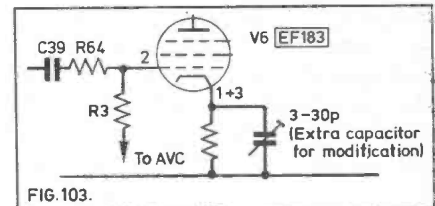

FIG. 103.

bias resistor in the RF amplifier stage V6 (see Fig. 103). A small value has been suggested for this capacitor since, with a more normal 10 or 100nF, the gain of this stage will become excessive on the lower bands, leading to poorer cross-modulation performance. The small trimmer can be set so that it only affects the higher bands. A further

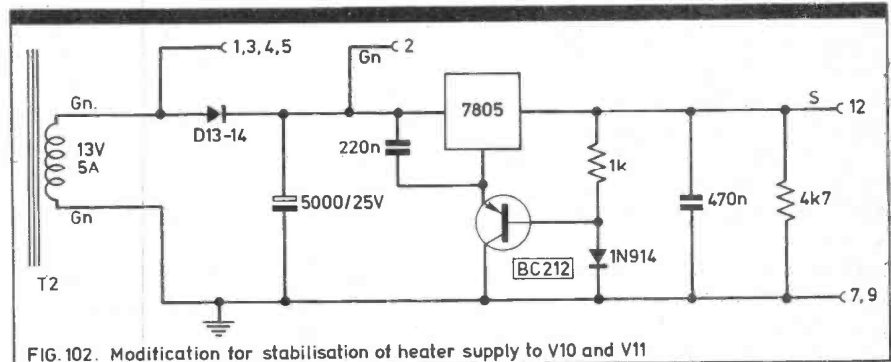

FIG. 102. Modification for stabilisation of heater supply to V10 and V11

snag is that a larger value may lead to the RF stage becoming unstable on 28MHz. A suitable component for this purpose is a Philips 'Beehive' trimmer, the central part being soldered to the earth tag adjacent to V6 on the side of the screen across the valveholder adjacent to pins 1 and 3. These two pins should be linked with a short piece of tinned copper wire and joined to the remaining terminal of the Beehive trimmer. To adjust after modification, tune up on transmit on 28MHz in the normal way, and do not touch the pre-selector after this. Switch to receive, tune to a steady incoming signal or inject a weak signal into the receiver, and set the trimmer to about half value. Adjust L5 for maximum signal as in the alignment procedure, and then check the operation of the preselector control to see whether its adjustment on receive seems to be unduly sharp. If so, reduce the capacitance of the Beehive trimmer, readjust L5 and try again. If, on the other hand, there seems to be little improvement in RF gain, increase the value of the trimmer, readjust L5 and try again. Note that the preselector peaks on receive and transmit should coincide. A convenient signal to use for these tests, particularly in the South of England where the writers live, is the GB3SX beacon. After finding the correct setting for the trimmer the operation of the receiver on 21 and 14MHz should be checked, adjusting the appropriate coils as described in the alignment section. The modification should have little or no effect on the performance on the other bands.

Improving the selectivity on CW

Two methods of improving the CW selectivity have been tried. The first, which is relatively cheap and simple, uses a single crystal and two miniature DIL relays, and despite its simplicity is fairly effective in use. To carry out this modification the coupling capacitor C21 between the mechanical filter and the grid of the first receive IF amplifier V13 is disconnected at the valveholder, and the circuit of Fig. 104 is inserted. A convenient method of construction is to assemble the components on a piece of *Lektrokit* board and mount this board on a small bracket adjacent to the mechanical filter. It is also

necessary to provide a switch on the front panel of the *KW2000* to switch the filter in and out of circuit. Since this switch only has to carry DC to the coils of RLA and RLB its position is not critical, and a convenient way of avoiding the necessity of drilling extra holes in the panel is to replace the calibrator push-button by a miniature three position toggle switch. This is wired so that the 'up' position activates the calibrator and the 'down' position switches in the CW filter, the centre position being for SSB operation. The relays RLA and RLB should be separate, rather than a single double-pole relay, in order to minimise signal leakage around the filter. The type used by the writers was RS Components type 349-399 in form C. No mechanical layout is given, since this will, to a large extent, depend on the components available, but it is advisable to keep all leads as short as possible, and to separate the input and output connections.

Once the filter has been installed, a temporary resistor of 4.7k ohms should be wired into the R_A position, the rig switched on and allowed to warm up. Tune to a CW signal of reasonable strength and switch the filter into circuit. A definite peak in signal strength should be found as the receiver tuning is varied. The width of this peak will depend on the value of R_A. Reducing the value narrows the peak and increasing the value widens it. There is, however, a tradeoff between selectivity and sensitivity, since reducing the value of R_A increases the insertion loss of the filter. The best value will usually lie in the range 1k to 10k, and will depend on the activity of the crystal,

so some experimentation will be necessary. It is as well to note that some use of the IRT control may be necessary in practice since the filter peak may not be at quite the same frequency as the transmitted signal. Until the modification to improve the keying characteristics (described later) is carried out, the exact transmitted frequency is dependent on the frequency of the sidetone oscillator since, as mentioned in part 1 of this series, CW is generated by keying this oscillator and feeding the resultant audio into the transmitter AF section.

The filter as just described was used for about a year by one of the authors and, whilst not perfect, it was found to be a vast improvement over having no filter at all. If CW is not your main mode you may find that it is adequate; however, if like both authors, you operate mainly on the key, you may well wish for something better, as is now described.

Fitting a mechanical filter for CW

The second, more complex method of improving the CW selectivity uses a Collins 455kHz mechanical filter of 500Hz bandwidth, and is definitely the better method of the two. The drawback is that the insertion loss of this type of filter is about 10dB, and some method of replacing this lost gain must be found. The writers used a dual gate MOSFET amplifier for this purpose; Fig. 105 shows a block diagram of the final set-up, and the circuit details are shown in Fig. 106.

A short note on the design philosophy behind this filter system may be of help at this point for the

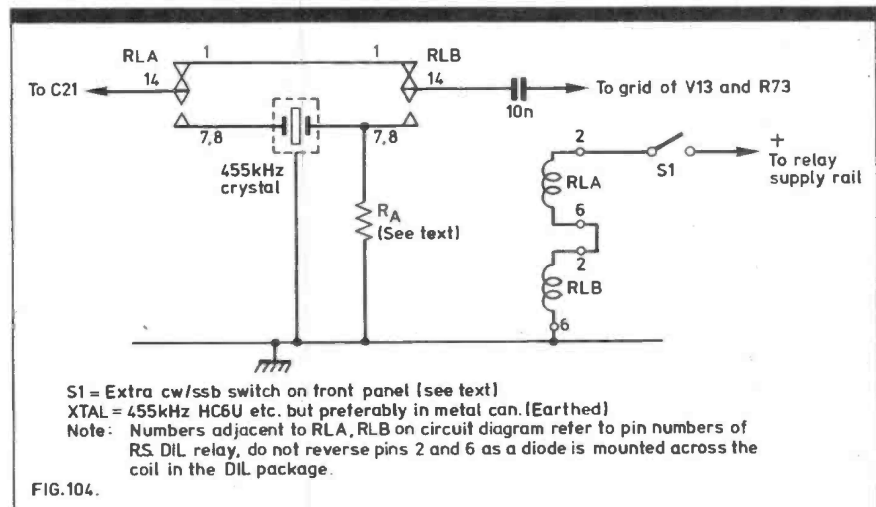

FIG.104.

